

July 2022

HUMBA ENVIRONMENTAL
CONSULTANCY

Basic Assessment Report: The proposed construction of the Ararat -Bafokeng 88kv Powerline within the Rustenburg Local Municipality, Northwest Province



DOCUMENT CONTROL

Degree of Confidentiality	Client Confidentiality
Title	Basic Assessment Report - The Proposed Construction of the Ararat- Bafokeng 88kv Powerline within the Rustenburg Local Municipality, Northwest Province
Date of Issue	May 2022
No. of Pages	54
Consultant details: HUMBA ENVIRONMENTAL CONSULTANCY 43 Montrose Street, Birchwood Court Vorna Valley, Midrand, 1685 Tel: 011 655 7301 Fax: 011 655 701 Email: tinashe@humba.org	Client details: ESKOM HOLDINGS SOC LIMITED-Gemma Cluster P.O BOX 1319 Rustenburg 0300 Tel: 012 725 2142 Cell: 079 962 4334 Email: MokaleMG@eskom.co.za
Compiled by	Ms Pfarelo Siebani
Peer reviewed by	Mr. Tinashe Maramba
Approved by	Ms Granny Mokaleng
Report Number	TAP/0421/ABNW-450
Copy Number	01
© The content, including format and ideas, is subject to copyright in terms of Copyright Act, Act 98 of 1978.	

ABBREVIATIONS

ARA/IMP	Ararat/Impala
BA	Basic Assessment
BAR	Basic Assessment Report
BPDM	Bojanala Platinum District Municipality
CA	Competent Authority
EMPr	Environmental Management Programme
DFFE	Department of Forestry, Fisheries and Environment
EAP	Environmental Assessment Practitioner
EIA	Environmental Impact Assessment
GDP	Gross Domestic Product
I&APs	Interested and Affected Party's
IDP	Integrated Development Plan
PPP	Public Participation Process
NEMA	National Environmental Management Act
SAMOAC	South African Manual for Outdoor Advertising Control

DEFINITIONS

"Activity" means an activity identified in Government Notice No. R. 983, 984 and No. R. 985 of 2014 as a listed activity.

"Alternatives", in relation to a proposed activity, means different means of meeting the general purpose and requirements of the activity, which may include alternatives to property, activity, design or technology.

"Applicant" means a person (including juristic person) who has submitted or intends to submit an application;

"Application" means an application for an environmental authorization in terms of Chapter 3 of the Environmental Impact Assessment Regulations, 2014.

"Associated Infrastructure" means any building or infrastructure that is necessary for the functioning of a facility or activity or that is used for an ancillary service or use from the facility.

"Cumulative impact", in relation to an activity, means the impact of an activity that in itself may not be significant but may become significant when added to the existing and potential impacts eventuating from similar or diverse activities or undertakings in the area.

"Development", means the building, erection, construction or establishment of a facility, structure or infrastructure, including associated earthworks or borrow pits, that is necessary for the undertaking of a listed activity, including any associated post development monitoring, but excludes any modification, alteration or expansion of such a facility, structure or infrastructure, including associated earthworks or borrow pits, and excluding the redevelopment of the same facility in the same location, with the same capacity and footprint;

"Environmental impact assessment", in relation to an application to which scoping must be applied, means the process of collecting, organizing, analysing, interpreting and communicating information that is relevant to the consideration of that application. A detailed study of the environmental consequences of a proposed course of the action, an environmental assessment or evaluation is a study of the environmental effects of a decision, project, undertaking or activity. It is most often used within an or evaluation is a study of the environmental effects of a decision, project, undertaking or activity. It is most often used within an Integrated Environmental Management (IEM) planning process, as a decision support tool to compare different options" (DEAT, 1998)

"Environmental Management Programme" means an environmental management plan in relation to identified or specified activities envisaged in section 19 and 23;

"Guidelines" means any national guidelines and provincial guidelines issued in terms of NEMA EIA regulations 2014.

"Interested and Affected Party" means an interested and affected party contemplated in section 24(4) (d) of the Act, and which in terms of that section includes -

(a) any person, group of persons or organization interested in or affected by an activity; and

(b) any organ of state that may have jurisdiction over any aspect of the activity;

"Public Participation Process" means a process in which potential interested and affected parties are given an opportunity to comment on, or raise issues relevant to, specific matters;

"Registered Interested and Affected Party", in relation to an application, means an interested and affected party whose name is recorded in the register opened for that application in terms of regulation 57.

"Significant impact" means an impact that by its magnitude, duration, intensity or probability of occurrence may have a notable effect on one or more aspects of the environment;

"Stakeholder", refers to a group of the public whose interests may be positively or negatively affected by a proposal or activity and/or who are concerned with a proposal or activity and its consequences. The term therefore includes the proponent, authorities and all I&APs.

"The Act" means the National Environmental Management Act, 1998 (Act No. 107 of 1998), as amended December 2014.

"Authority", refers to the national, provincial or local authorities that have a decision-making role or interest in the proposal or activity. The term includes the lead authority, as well as other authorities.

"Focus group meeting" refers to a group who have a significant common interest around a particular issue or geographic area, e.g., farmers associations, conservation/ecotourism associations, ratepayer's associations, etc.

CONTENTS

1. BACKGROUND	1
1.1 Introduction.....	2
1.2. Existing Infrastructure.....	3
2. PROJECT LOCALITY	3
3. ACTIVITIES OF THE PROJECT.....	5
3.1. Activity to be undertaken.....	5
3.2. Listed Activities	9
4. LEGISLATIVE CONTEXT.....	10
5. NEED AND DESIRABILITY	11
6. ALTERNATIVE ASSESSMENT	11
6.1. Route Alternatives	11
6.1.1. Ararat Route Option A.....	11
6.1.2. Ararat Route Option B.....	11
6.1.3. Bafokeng Route	15
6.2. Technology Options	15
6.2.1. Overhead Power cables.....	15
6.2.2. Underground Power cables.....	16
6.3. No Go Option	16
7. SITE PICTURES.....	16
8. SOCIO ECONOMIC CHARACTER OF STUDY AREA.....	20
9. PUBLIC PARTICIPATION PROCESS	21
9.1. Purpose of the Public Participation.....	21
9.2. Interested and Affected Parties (I&APs) Identification.....	22

9.3. Notification of BA Process	22
9.3.1 Advert.....	22
9.3.2 Site Notices.....	22
9.3.3 Public Involvement and Consultation	23
9.3.4 Availability of Draft BAR	23
9.3.5. Public Meetings.....	23
10. ENVIRONMENTAL ATTRIBUTES/RECEIVING ENVIRONMENT	23
10.1 General Biophysical Environment	24
10.1.1 Climate.....	24
10.1.2 Surface Hydrology.....	25
10.1.3 Regional Vegetation.....	27
10.1.4 Conservation & Protected Areas.....	27
10.1.5 Geology.....	30
10.1.6 Heritage	31
10.1.7. Soils and Land-Use and Land capability	31
11. 11. IMPACT ASSESSMENT.....	33
11.1 The Impact Assessment aimed to achieve the following:	33
11.2. Methodology of Impact Assessment.....	33
12. POTENTIAL CUMULATIVE IMPACTS.....	48
12.1 Impacts on the Infrastructure Development.....	48
12.2 Impacts on Ecological Resources	49
12.4 Socio-economic Impacts	50
13. IMPACT ASSESSMENT AND SUMMARY	50
14. ENVIRONMENTAL MANAGEMENT PROGRAMME REPORT.....	53
15. SPECIALIST RISK MATRIX.....	53
16. CONCLUSION AND RECOMMENDATION	53
16.1. Reasoned opinion why the project must go ahead.....	53

16.2. Environmental Impact Statement 54

TABLE OF FIGURES

Figure 1: Figure showing the relative locations of Ararat MTS and the Bafokeng 7 Substation..... 4

Figure 2: D-DT 7618 type tower technology 6

Figure 3: D-DT 7645 (Strain) type tower technology..... 7

Figure 4: Access road identified at Ararat MTS 8

Figure 5: Alternative Ararat route options A and B..... 13

Figure 6: Route option at Bafokeng 7 DS site..... 14

Figure 7: Entrance to Ararat Main Transmission Substation..... 17

Figure 8: Separate Ararat-Bafokeng (ARA/BAF) lines (middle two) after conjoint out of Ararat MTS 17

Figure 9: Existing low-lying D-DT 7618 tower structures taking power from Ararat MTS which are proposed for Ararat Alternative Route A..... 18

Figure 10: 1 ARA/IMP 6 where Ararat Alternative Route B is proposed 18

Figure 11: Bafokeng 7 Substation 19

Figure 12: Image showing point at which the ARA/BAF lines from Ararat MTS join into one single line into Bafokeng 7 substation 19

Figure 13: Anthropogenic activities (residential housing and dumping) taking place within 100m of the ARA/BAF powerline 20

Figure 14: Wind Roses for the project area 25

Figure 15: Hydrological Map of the study area 26

Figure 16: Regional vegetation types onsite..... 28

Figure 17: Map showing the proposed sites do not traverse any CBA's 29

Figure 18: Geology of the study area..... 32

LIST OF TABLES

Table 1: Project Location Details 3

Table 2: Specialist studies that were excluded from the study..... 9

Table 3: Listed Activities Triggered..... 10

Table 4: Applicable Legislation, Policies and Guidelines 10

Table 5: Coordinates of points of interest; Ararat Site 15

Table 6: Coordinates of points of interest; Bafokeng Site..... 15

Table 7: Significance Ratings 35

Table 8: Planning and Design Phase Impacts 37

Table 9: Construction Phase Impacts..... 40

Table 10: Operational Phase Impacts..... 46

Table 11: Decommissioning Phase Impacts..... 47

Table 12: Table of Impact for Infrastructure Development..... 49

Table 13: Table of Impact for Ecological Resources..... 49

Table 14: Table of Impact for Socio-economic Activities 50

Table 15: Impact Summary Table..... 51

Table 16: Specialists Option Matrix Table 53

1. BACKGROUND

Eskom Holdings SOC Limited (ESKOM) is mandated by the South African Government to ensure the provision of reliable and affordable power to South Africa. ESKOM currently generates approximately 95% of the electricity used in South Africa. Therefore, electricity must be generated in accordance with supply demand requirements. ESKOM's core business is the generation, transmission and distribution of electricity.

The reliable provision of electricity by ESKOM is critical for industrial development and related employment and sustainable development in South Africa. As electricity cannot be stored, power is generated and delivered over long distances at the very instant that it is required. In South Africa, thousands of kilometres of high voltage Transmission lines (i.e., 765 kV, 400 kV and 275 kV transmission lines) transmit this power to ESKOM's major substations. At these major substations, the voltage is downrated and distributed to smaller substations all over the country via Distribution lines (e.g., 132 kV, 88 kV and 66 kV power lines). Here the voltage is down-rated further for distribution to industry, businesses, farms and homes. In order to maintain a reliable power supply within the entire network, the voltages at all substations are required to be within certain desired limits.

In line with the mandate stated above, ESKOM has a tier of clients referred to as Premium Clients who require a non-interruptible and constant source of power supply such as industries and mines. As such, the proposed project was borne from a request by Impala Platinum Holdings Limited's (Implats) Impala Rustenburg Operations for an increase in the notified maximum demand (NMD) from 59 to 85MVA at the Bafokeng 7 88/33/11kV substation that supplies the Rustenburg operations directly.

Why Is An Environmental Impact Assessment Process Necessary?

The Department of Forestry, Fisheries and Environment (DFFE) identified certain activities that may have a detrimental impact on the environment. In order to ensure that the potential negative and positive impacts are investigated, understood, and mitigated (made less severe) the DFFE promulgated regulations under the National Environmental Management Act (Act 107 of 1998) that;

- (a) identify the activities that require a Basic Assessment (BA) or Full Scoping and Environmental Impact Assessment (S&EIA); and
- (b) govern how these studies must be conducted. These regulations are called the EIA Regulations of December 2014 as amended April 2017 and can be found in Gazette No. 40772 and consist of the following regulations:
 - Regulation 326 – Environmental Impact Assessment Regulations.
 - Regulation 327 – Listing Notice 1.

- Regulation 325 – Listing Notice 2.
- Regulation 324 – Listing Notice 3.

These regulations are used by applicants (ESKOM in this case) and Environmental Assessment Practitioners (EAPs) to decide what studies need to be conducted.

In order to firm up supply at the Bafokeng 7 substation, ESKOM must construct and operate an 88kV distribution power line “coming out” of the Ararat Main Transmission Substation (MTS) and “going into” the Bafokeng 7 Substation. As such, some activities in Listing Notice 1 are triggered. In light of this, ESKOM has appointed Humba Environmental Consultancy (Humba) through Trans Africa Projects (TAP) to act as an independent EAP and subsequently conduct all the activities related to formulating a Basic Assessment Report (BAR) and submit it to the Competent Authority (CA). The CA then uses the information in the BAR and associated appendices to decide whether the activity can be positively authorised (given the go-ahead) and what conditions are necessary to protect the socio-economic and natural environments, or if the proposed project will be too detrimental to the environment and must be stopped from being implemented.

1.1 Introduction

Eskom's Bafokeng 7 substation currently supplies electricity directly to Impala platinum mine and a number of existing powerlines run into the substation. Eskom proposes to add further capacity at Eskom Bafokeng 7 substation for Impala Platinum mine by reducing electricity load at Millennium Substation which feeds Millennium mine and increasing/taking it to Bafokeng 7 substation which will supply more electricity load for Impala Platinum mine and the local townships of Mogono and Ga-Luka by executing the following scope of work;

- the splitting of the 2xSycamore 88kV lines that are entering the Bafokeng 7 88/33kV substation and the 2xSycamore 88kV lines that are also leaving the Eskom Ararat Main Transmission Substation (MTS), so as to increase a load for Impala Platinum mine while maintaining a firm supply at Eskom's Millennium 88/33/6.6kV substation by shifting load from the Millennium point of supply to Eskom's Bafokeng 7 substation.

In addition, Eskom Bafokeng 7 substation supplies the local townships of Mogono and Ga-Luka. The Ararat MTS supplies local substations like Minpro, SA Chrome, Millennium, Impala Platinum, Phokeng, Wildeplats and Bafokeng 7.

1.2. Existing Infrastructure

Currently, at Ararat MTS, four (4) high voltage powerlines run into the substation from the west of the substation. There are eight (8) low voltage powerlines running out of the substation due east. The Ararat MTS is fenced off and includes but not limited to a guard house, offices, parking bays, feeder bays

At Bafokeng Substation, eleven (11) low voltage powerlines run into the substation. The powerlines then feed the existing Impala Platinum mine and the surrounding communities of Ga-Luka and Mogono with electricity. The substation is fenced off and includes inter alia 3 feeder bays.

2. PROJECT LOCALITY

The proposed project will be in the Rustenburg Local Municipality (RLM) under the magisterial municipal district of Bojanala Platinum (BPDM). Ararat MTS is approximately 4km due north-east of Phokeng town, capital of the Royal Bafokeng Nation. Bafokeng 7 substation is located between the Ga-Luka and Magono townships, Rustenburg. Ararat MTS is approximately 7.5km due south of Bafokeng 7 substation (see Figure 1 below)

Table 1: Project Location Details

Property description/ Physical address and Farm Names	
Province	Northwest Province
District Municipality	Bojanala Platinum District Municipality
Local Municipality	Rustenburg Local Municipality
Farm Names	Doornspruit 106 JQ and Kookfontein 265 JQ

The proposed line route at Ararat Option A is 244.32m whilst at Ararat Option B, the length is 574.83m. The proposed Bafokeng 7 Line is 394.76m.

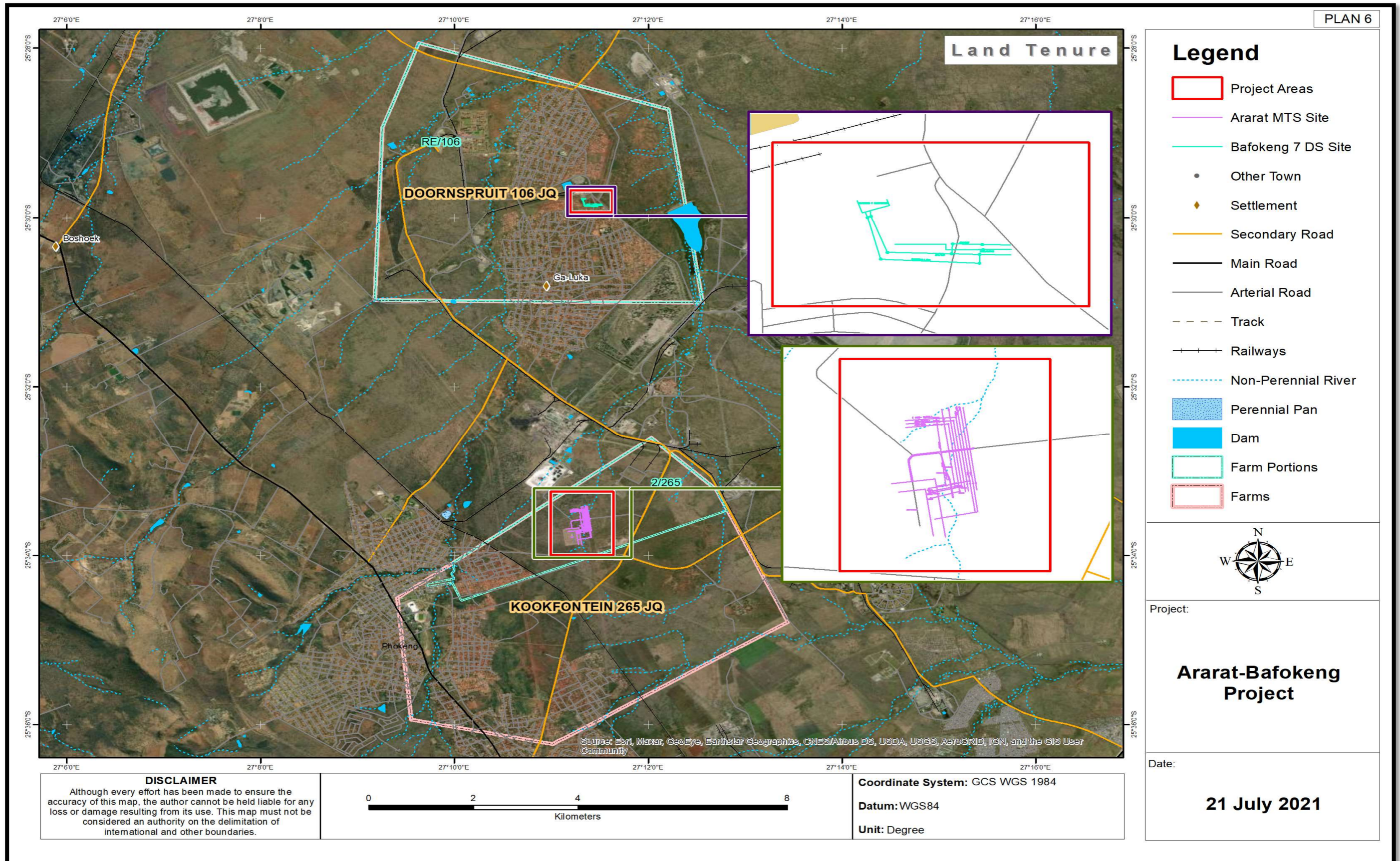

Figure 1: Figure showing the relative locations of Ararat MTS and the Bafokeng 7 Substation

3. ACTIVITIES OF THE PROJECT

3.1. Activity to be undertaken

ESKOM is proposing to build two separate sections of 88kV distribution powerline by splitting the 2xSycamore 88kV lines entering Bafokeng 88/33kV substation and leaving Ararat MTS.

- **Line clearances**

Low voltage power lines require a fair amount of clearance area for safety precautions. The Occupational Health and Safety Act, 1993 (Act No. 85 of 1993) provides for statutory clearances.

- **Servitude requirements for the proposed power line**

The proposed 88kV power line will require specialists to study a corridor 100m wide in order to accommodate a servitude width of 31m (15.5m either side of the centre line of the power line). Any extra area required outside the servitude shall be negotiated with the relevant land occupiers and approved by ESKOM. All areas marked as no-go areas, identified by means of the environmental assessment process, located inside the servitude shall be treated with the utmost care and responsibility. If any environmental and/or socio-economic concerns within the servitude width are found within the proposed power line, the 50m width shall provide ESKOM with ample wiggle room to avoid any environmental and/or socio-economic concerns. The ESKOM Standard and specifications for vegetation clearance and invasive alien plant management for new power line construction specifications have been incorporated into the Environmental Management Programme (EMPr), which will guide the construction, operational and maintenance phases of the project.

- **Towers installation**

The proposed tower technology to be employed will be the D-DT 7618 (Strain) which is a 3-pole strain structure (see Figure 2 below) and the D-DT 7645 (Strain) which is a guyed strain structure (see Figure 3 below).

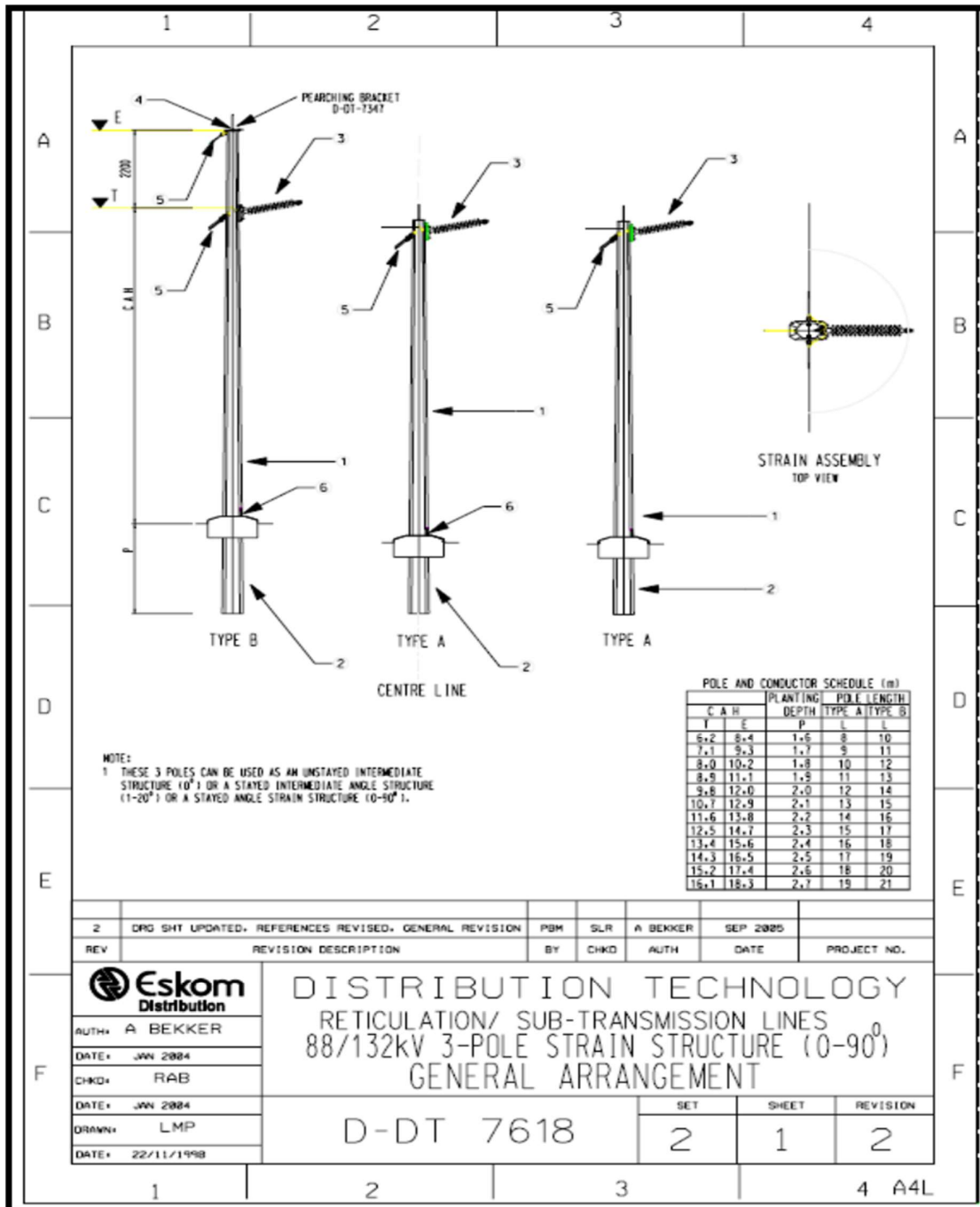

Figure 2: D-DT 7618 type tower technology

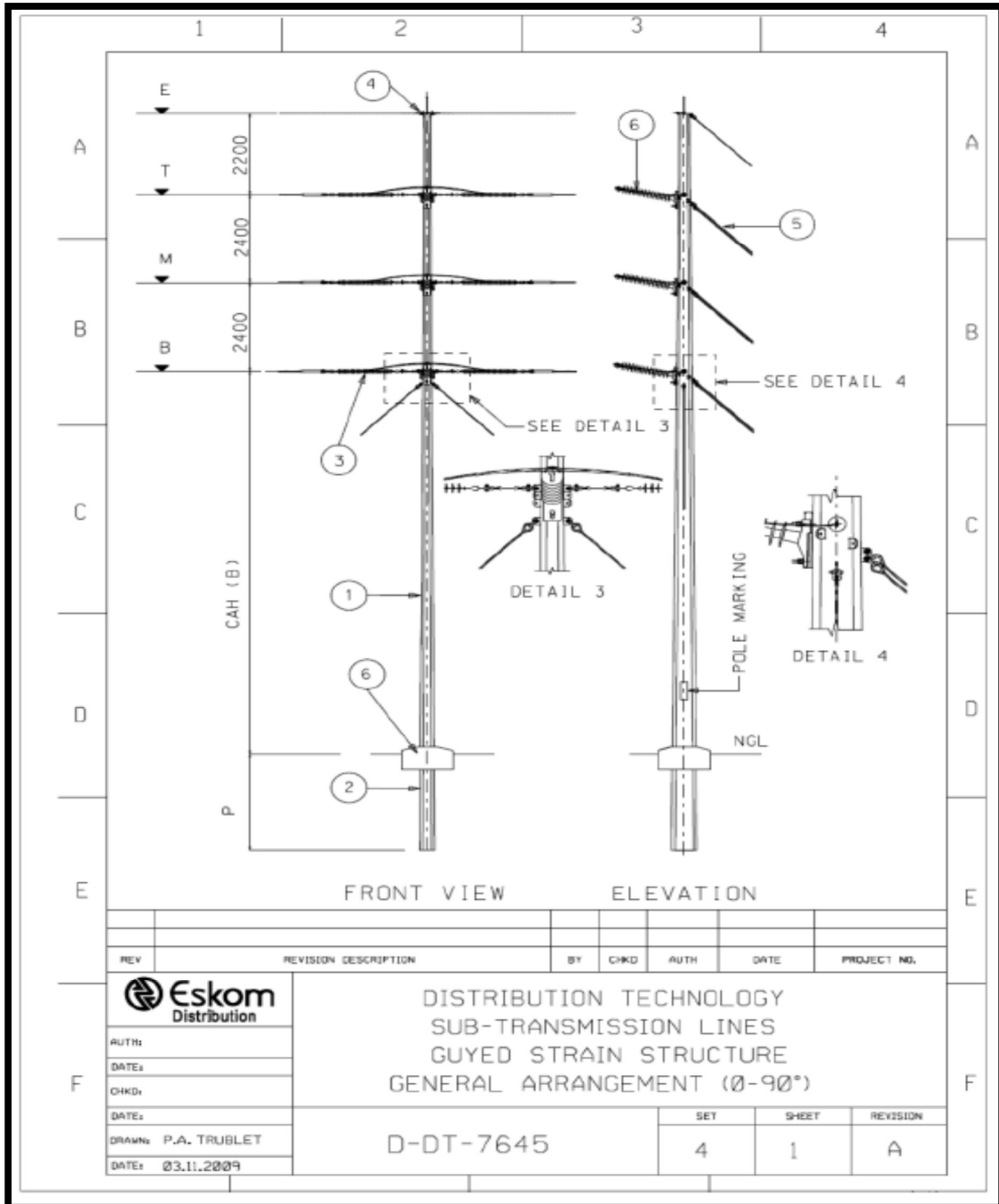

Figure 3: D-DT 7645 (Strain) type tower technology

- **Road Access for Construction and Maintenance of the 88kV power lines**

Road access will be required as part of the servitude along the distribution line for easy access during the construction, and maintenance of the distribution line. There is existing access at the Ararat MTS as shown by Figure 4 below. Access will need to be negotiated at the Bafokeng 7 substation site.



Figure 4: Access road identified at Ararat MTS

- **Specialist studies**

Several specialist studies were conducted to provide more detailed information on the environment aspects that may be affected by the proposed project. These studies addressed Ecological (Flora, Fauna and Avifauna), Watercourse (Hydrology), Palaeontology and Heritage aspects. The specialist reports are attached as an appendix to this BAR. As per the generated Screening Report some specialist studies were excluded. Table 2 below shows the excluded specialist studies together with the motivations for exclusion;

Table 2: Specialist studies that were excluded from the study

Specialist study identified Screening Tool	Motivation for exclusion
Agriculture Theme Sensitivity	An assessment of the study area showed no discernible agricultural practices of concern. However, cattle were found to graze around the Ararat Substation.
Aquatic Biodiversity Theme Sensitivity	No aquatic features occur within the study area.
Civil Aviation Theme Sensitivity	No airports were observed within a 5km radius of the project area with the closest airport being the Rustenburg Airfield which is 12km due south-east of the Ararat Transmission Substation
Defence Theme Sensitivity	No defence activity was observed within a 5km radius of the site.

- **Construction Site Camps**

The Contractor appointed for the construction of the power line may set up site camps. Alternatively, the contractor may however prefer to use a fully serviced site in another location. **The construction site camp will be located within the approved 100m corridor.** The corridor has been made wide enough to facilitate the location of an adequate site camp within an environmentally assessed corridor. The location of the site camp will be determined by the contractor during construction based on viability

3.2. Listed Activities

The proposed construction of the 88kV Ararat-Bafokeng distribution power lines triggers listed activities in terms of the National Environmental Management Act (NEMA), 1998 (Act No 107 of 1998). The activities triggered by the proposed 88kV distribution power line are listed in Table 3 below. The table gives the Government Notice Number under which the activity is triggered, activity number, activity description in terms of NEMA, and the description of the activity itself in relation to that of the description of the activity being triggered.

Table 3: Listed Activities Triggered

Listed activity as described in R327	Description of project activity
No. 11(i): The development of facilities or infrastructure for the transmission and distribution of electricity outside urban areas or industrial complexes with a capacity of more than 33 but less than 275 kilovolts	The proposed project entails the development of facilities and infrastructure for the distribution of electricity. The proposed line is 88kV

4. LEGISLATIVE CONTEXT

The following legislation, regulations and or guidelines may be applicable for the proposed construction of an 88kV Ararat-Bafokeng distribution power line as part of the Basic Assessment.

Table 4: Applicable Legislation, Policies and Guidelines

Title of legislation, policy or guideline	Applicability to the project	Administering authority	Date
National Environmental Management Act (NEMA) (Act No 107 of 1998).	The proposed development of an 88kV power line requires an Environmental Authorisation (EA) in terms of NEMA.	DFFE	1998
Environmental Impact Assessment Regulations Government Notice No.326 & Listing Notice 1 Government Notice No. 327	The proposed development of an 88kV power line, requires an Environmental Authorisation (EA) in terms of NEMA and triggers activities listed in Notice 1 of Government Notice No. 327	DFFE	2014 as amended
Integrated Environmental Management (IEM) Guidelines of the National Department of Forestry, Fisheries and Environmental Affairs	The proposed activity is a linear development and runs some aspects of the surrounding environment are considered sensitive, therefore the IEM is considered.	DFFE	2002
National Heritage Resources Act (Act No. 25 of 1999)	Heritage Impact Assessments were conducted, and is under the jurisdiction of SAHRA, this is to ensure that adequate processes are followed in case archaeological artefacts are uncovered during the proposed development.	SAHRA	1999
National Environmental Management: Waste Act (Act No. 59 of 2008).	The act will ensure that all waste generated by the proposed development during the construction, will be disposed of in line with the requirements of the waste act, for safe disposal of waste.	DFFE	2008
National Environmental Management: Air Quality	The National Ambient Air Quality Standards ensure that the proposed	Rustenburg Local	2014

Act (Act No. 39 Of 2004).	development is undertaken within the confines of the ambient levels for emissions resulting from the proposed development.	Municipality	
National Environmental Management: Biodiversity Act (Act No. 10 Of 2004).	The proposed route options do not overlap with any protected or conservation area, however, a monitoring program to control and/or eradicate newly emerging alien invasive plant species and the rehabilitation of disturbed areas should receive high priority.	DFFE	1989

5. NEED AND DESIRABILITY

The Ararat MTS supplies local substations like Minpro, SA Chrome, Millennium, Impala Platinum, Phokeng, Wildeplats and Bafokeng 7. Currently Eskom Bafokeng 7 substation does not only supply Impala Platinum mine but it also supplies the local townships of Mogono and Ga-Luka. The proposed project will;

- assist that the inhabitants of these townships will be supplied with a reliable and firm power source; and
- assist Impala Platinum mine with its operations with an increased power load.

6. ALTERNATIVE ASSESSMENT

6.1. Route Alternatives

6.1.1. Ararat Route Option A

Ararat Route Option A will involve;

- Building a new 244.32m line from the substation to interconnect with existing Bafokeng line and run underneath the existing lines at a 90° angle (see Figure 5 below).

6.1.2. Ararat Route Option B

The 574.83m Ararat Route Option B will involve rerouting the existing 1Ararat/Impala (ARA/IMP) line by;

- Building a new 550m line from the substation to a point just before structure number 1ARA/IMP 6.
- Dismantling 1 span between 1ARA/IMP 5 & 6.
- Interconnect Bafokeng 7 line to Impala line at structure number 1ARA/IMP5

Figure 5 and Figure 6 below show the alternative routes with the 100m corridor applied to all alternative routes.

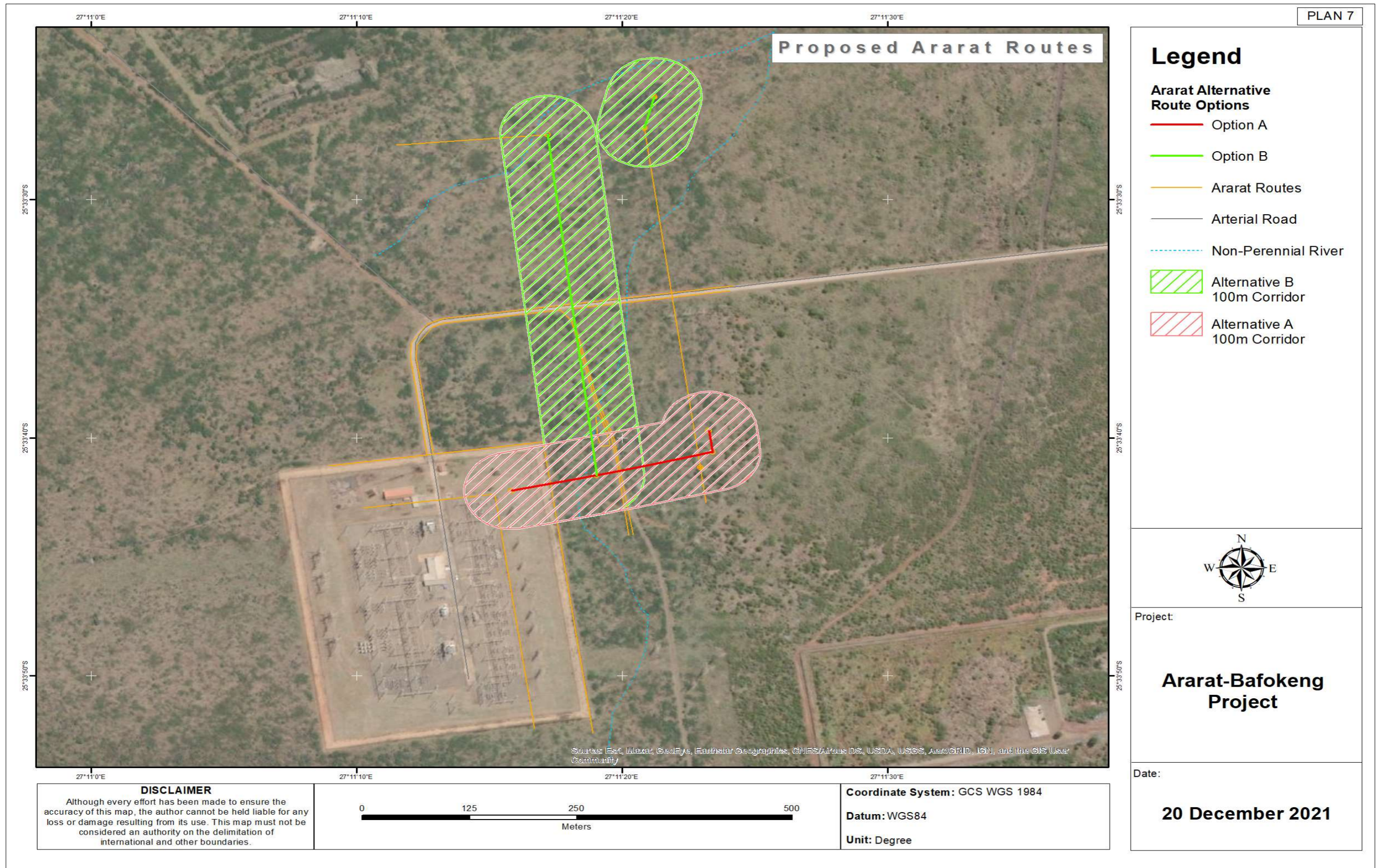

Figure 5: Alternative Ararat route options A and B

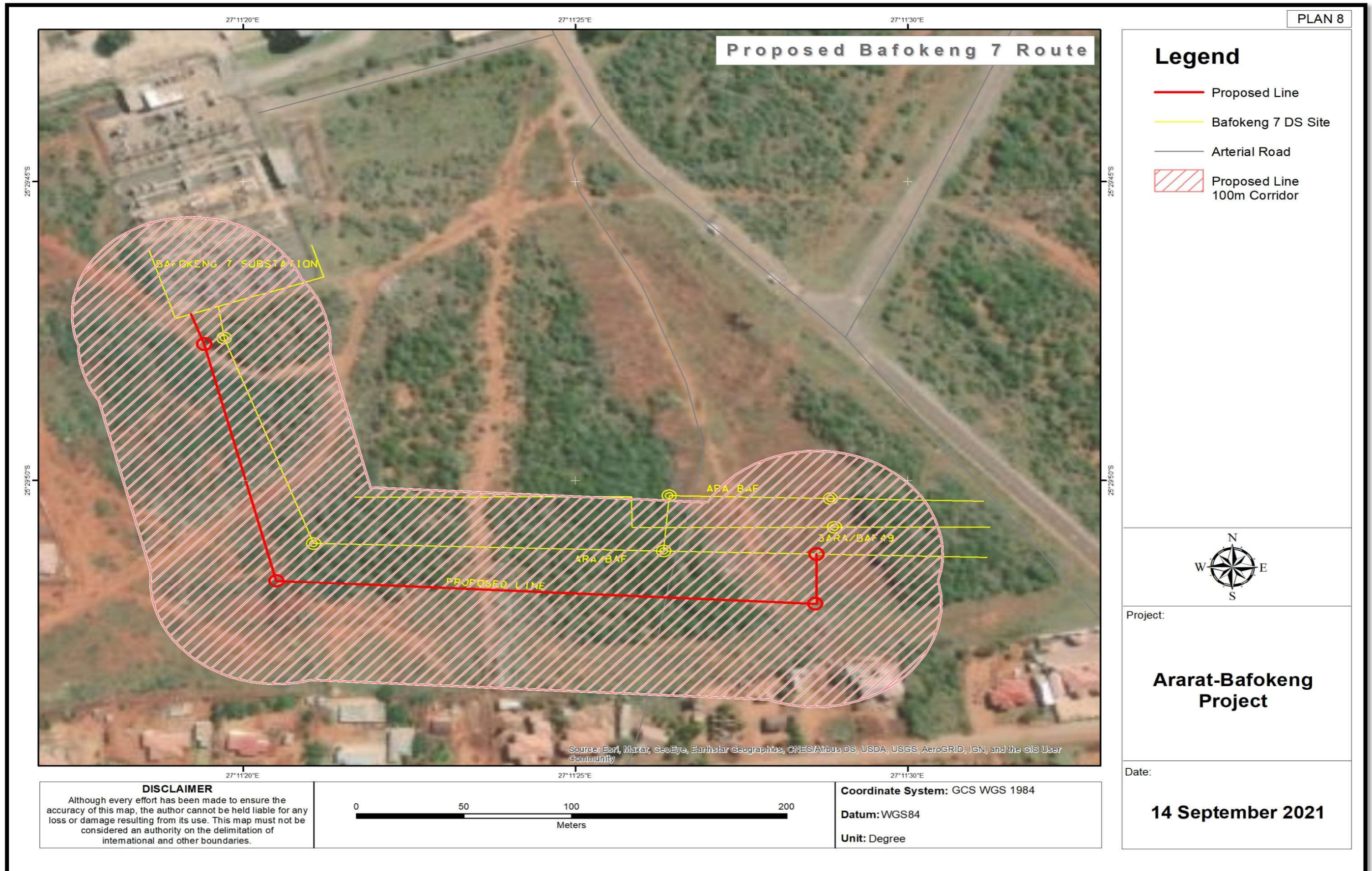

Figure 6: Route option at Bafokeng 7 DS site

Table 5 below shows the coordinates of points of interest as they relate to the Ararat Route Alternatives Options.

Table 5: Coordinates of points of interest; Ararat Site

Marker Name	Point Name	DMS	
		Lat	Long
Ararat Route Option A	Start Point	25° 33' 42.21" S	27° 11' 15.84" E
	Middle Point	25° 33' 41.55" S	27° 11' 19.03" E
	End Point	25° 33' 39.69" S	27° 11' 23.27" E
Ararat Route Option B	Start Point	25° 33' 42.21" S	27° 11' 15.84" E
	Middle Point	25° 33' 34.41" S	27° 11' 18.16" E
	End Point	25° 33' 25.69" S	27° 11' 21.19" E
Access Road Point		25° 33' 34.55" S	27° 11' 17.97" E

6.1.3. Bafokeng Route

The 394.76m Bafokeng route chosen by ESKOM's survey and engineering team was the **only feasible option** based on the configuration of the site as per the existing lines running into and out of the Bafokeng 7 substation. As such, the route option is preferred from a technical sense as the existing powerlines into Bafokeng 7 Substation do not allow for other route options. The existing network around Bafokeng 7 as well as the orientation of the substation allows for only **one option**. The 88kV Busbar inside the station has only one side available for installation of an additional feeder bay. The other sides are already occupied by 88kV and Impala lines leaving the station. See Figure 6 above for the Bafokeng Route map.

Table 6 below shows the coordinates of points of interest as they relate to the Bafokeng 7 Route.

Table 6: Coordinates of points of interest; Bafokeng Site

Marker Name	Point Name	DMS	
		Lat	Long
Bafokeng Route Option	Start Point	25° 29' 47.22" S	27° 11' 19.21" E
	Middle Point	25° 29' 51.67" S	27° 11' 20.49" E
	End Point	25° 29' 51.22" S	27° 11' 28.62" E
Access Road Point		25° 29' 51.48" S	27° 11' 32.97" E

6.2. Technology Options

6.2.1. Overhead Power cables

From an operational point of view overhead power lines are considered preferable as ESKOM has the responsibility to provide cost effective and reliable energy resources. Another important factor is that

overhead lines can generally span over and not disturb sensitive features such as cultural resources sites, streams, wetlands, isolated steep slopes, and sensitive species habitat. The other advantage is that overhead lines are constantly cooled by air/wind while underground lines need oil for cooling.

6.2.2. Underground Power cables

Underground power lines are oil cooled, requiring sealed conductors significantly larger in diameter than overhead conductors, which are air-cooled. The larger conductors will automatically require a larger servitude to keep the conductors apart. The significance with the servitude for an underground power line is that the line would need to be buried to a depth of between 1.5m and 2m, generating significant spoil that will need to be disposed of. Additionally, the potential for pollution to underground water resources in case of oil spills, etc. is extreme. The servitudes would need to be kept in an open, grassed fashion. Not only is this inappropriate for some parts of the study area, but, importantly for landowners, the servitude area becomes sterile for the purposes of continued agricultural or other activities as absolutely no activity can be allowed on the servitude.

6.3. No Go Option

By not taking any action, ESKOM would not be able to supply Impala Platinum with the required NMD to allow for the continuous operation of mining activities. This would leave the mining operations at risk were there to be any unforeseen issues on one of the cojoined powerlines, i.e., without the N-1 contingency.

The No-go Option would reduce the impact on the aesthetic value of the natural environment because the introduction of power lines into the landscape changes the sense of place. It would also benefit the status quo of the biophysical environment. However, the need for a reliable supply of electricity to the mine could create stunted economic growth for the surrounding areas.

7. SITE PICTURES

The following are pictures of the study area for the proposed 88kV Ararat-Bafokeng distribution power line.



Figure 7: Entrance to Ararat Main Transmission Substation



Figure 8: Separate Ararat-Bafokeng (ARA/BAF) lines (middle two) after conjoint out of Ararat MTS



Figure 9: Existing low-lying D-DT 7618 tower structures taking power from Ararat MTS which are proposed for Ararat Alternative Route A

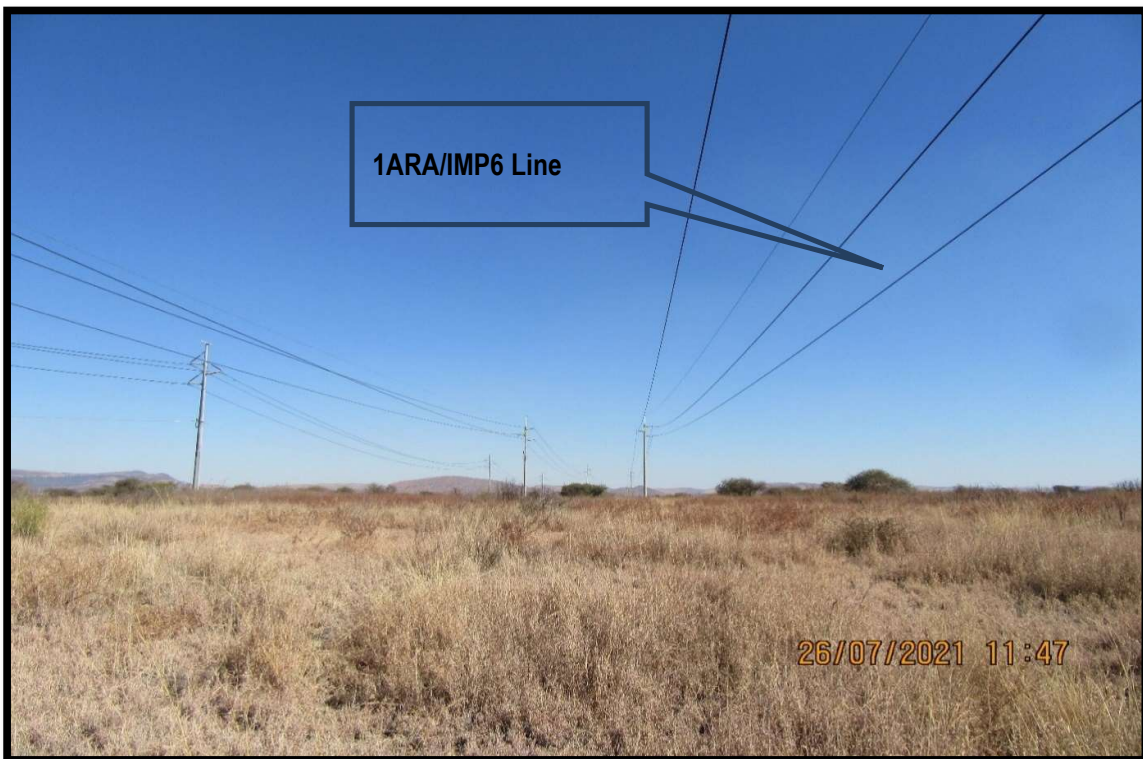

Figure 10: 1 ARA/IMP 6 where Ararat Alternative Route B is proposed



Figure 11: Bafokeng 7 Substation



Figure 12: Image showing point at which the ARA/BAF lines from Ararat MTS join into one single line into Bafokeng 7 substation



Figure 13: Anthropogenic activities (residential housing and dumping) taking place within 100m of the ARA/BAF powerline

8. SOCIO ECONOMIC CHARACTER OF STUDY AREA

The proposed development of the 88kV power line segments will be within the platinum rich RLM which forms part of BPDM. The smaller towns of Ga-Luka and the Phokeng form part of the 27 000 acres of land predominantly owned by the Bafokeng Tribe (now known as the Royal Bafokeng Nation) which were, in the 1960s, signed over to form the Impala Platinum mining company. Ga-Luka and Phokeng are two of 29 villages that make up the Royal Bafokeng Nation.

The RLM accommodates about 16% of the provincial population, and it is estimated that it will in future experience significant population growth (up to 32.9% of the provincial population growth). Rustenburg town represents the centre of population concentration, employment opportunities and shopping opportunities. This attracted urban development towards the town. With 645 000 people, the Rustenburg Local Municipality housed 1.1% of South Africa's total population in 2017. Based on the present age-gender structure and the present fertility, mortality and migration rates, Rustenburg's population is projected to grow at an average annual rate of 1.7% from 645 000 in 2017 to 700 000 in 2022 (RLM, 2019/2020).

The primary sector consists of two broad economic sectors namely the mining and the agricultural sector. Between 2007 and 2017, the agriculture sector experienced the highest growth in 2017 with an average growth rate of 43.3%. The mining sector reached its highest point of growth of 19.5% in 2015. The agricultural sector experienced the lowest growth for the period during 2015 at -18.2%, while the mining sector reaching its lowest point of growth in 2014 at -13.0%. Both the agriculture and mining sectors are generally characterised by volatility in growth over the period (RLM, 2019/2020).

9. PUBLIC PARTICIPATION PROCESS

This section of the Basic Assessment Report incorporates the details of the public participation process (PPP) for the proposed construction of an 88kV Ararat-Bafokeng distribution power line, as required in terms of Chapter 6 of the EIA regulations of 04th December 2014 as amended 07th April 2017.

It must be noted that a PPP process was undertaken from the **25th of March 2022 to the 27th of April 2022**. As such, all PP media from that period is deemed valid up to and within a period of **six (6) months**. Such PP media includes site notices and the distributed BID's. However, as new information will be installed into the BAR appendices, a new newspaper advert will be flighted for this current PPP to give effect to Section 41(2) (c) of the 2014 EIA Regulations (as amended).

9.1. Purpose of the Public Participation

The public participation process as contemplated in NEMA, aims to provide access to information that has reasonably or may have potential to influence any decision by the competent authority with regard to an application unless access to that information is protected by law and must include consultation with-

- (a) The competent authority;
- (b) Every State department that administers a law relating to a matter affecting the environment relevant to an application for an environmental authorization;
- (c) All organs of state which have jurisdiction in respect of the activity to which the application relates; and
- (d) All potential, or, where relevant, registered interested and affected parties.

It further provides the competent authority and registered interested and affected parties (I&APs), with an opportunity to comment on reports and plans contemplated in sub-regulation (1) of NEMA.

9.2. Interested and Affected Parties (I&APs) Identification

It was eminent to identify relevant stakeholders, and I&APs during the public consultation process, to contribute to the process. The registration of I&APs allows for dissemination of information regarding the project, and for activities to be undertaken in a transparent manner, which afford stakeholders and I&APs the opportunity to voice their concerns and or views as required in Chapter 6 of the NEMA and EIA regulations of 04th December 2014 as amended 07th April 2017.

9.3. Notification of BA Process

9.3.1 Advert

In order to notify and inform the public, stakeholders and I&APs of the proposed 88kV Ararat-Bafokeng distribution power line, an advert will be placed in print media. The public and or stakeholders and I&APs will be invited to register their comments on the project, by placement of an advertisement in the locally circulated **Platinum Weekly Newspaper**, on the **29th of July 2022** in line with the requirements of NEMA in Section 41(2) (c). The advert will contain amongst others, the following information required:

- Details of the application or proposed application;
- The process applied for whether Basic Assessment (BA) or S&EIR, in this regard, BA;
- The nature and location of the activity to which the application relates;
- Details of the EAP, where further information can be obtained; and
- The manner which, representations in respect of the application or proposed application may be made i.e., comments, queries and suggestions etc.

It must be noted that an advert informing the public of the project was initially flighted on the **25th of March 2022** in the Platinum Weekly. However, due to the addition of new information, i.e., Generic EMP, to the BAR appendices, another advert, as mentioned above, will be carried by the Platinum Weekly to give effect to Section 41(2) (c) of the NEMA Regulations and thus give the public and or stakeholders and I&APs and opportunity to review and comment on the new information.

9.3.2 Site Notices

The process of flighting the prior press advert in print media was preceded (a day earlier) by the installation of site notices in and around the proposed development sites. The 30-day public participation commenting period then started on the same day that the newspaper ads were be published. Site notices

in A3 size were placed at strategic locations near the study area on the **24th of March 2022**. Site notices were particularly placed along the Route Options and at all affected communities, including schools and other public amenities like libraries and healthcare facilities.

9.3.3 Public Involvement and Consultation

Relevant information regarding the proposed 88kV Ararat-Bafokeng distribution power line was detailed in a Background Information Document (BID) for the project. The BID was distributed on the **24th of March 2022** to identify stakeholders; additional copies were made available at a public venue within the broader study area. Stakeholders and I&APs were given an opportunity to raise their issues and concerns which would be documented in the Final Basic Assessment Report.

9.3.4 Availability of Draft BAR

The Draft BAR (DBAR) will be made available to the public to comment on the contents therein from the **29th of July 2022 to the 29th of August 2022**. Hard and soft copies of the DBAR will be dropped off at the following locations:

Venue	Contact Details
SAPS, Phokeng, Salema Section, Phokeng, 0300	Tel.:(+27) 14 566 1879
Bafokeng Mall Library	Tel.:(+27) 11 731 9000
Thethe Secondary School, Ga-Luka, 0322	Tel.:(+27) 11 855 7364
Mogono Primary School, Mogono, 0328	Tel.:(+27) 73 776 0600

9.3.5. Public Meetings

No public meeting will be held during the public participation period, however, should any member of the community in any capacity feel the need to meet with the EAP and/or Eskom team, that member shall be granted latitude to have the meeting either virtually or face to face. The minutes of the meeting will duly be appended to the Final BAR.

10. ENVIRONMENTAL ATTRIBUTES/RECEIVING ENVIRONMENT

This section of the Basic Assessment Report provides a description of the environment that will be affected by the proposed development. This information was provided in order to assist the reader / authorities/ I&APs in understanding the receiving environment within which the proposed development is to take place. Features of the biophysical, social and economic environment that will be directly or indirectly affected or could be affected by the proposed development have been described. This

information had been sourced from both existing information available for the area (desktop studies) as well as collected data from the field with the aim of proving the context within which this BA has been conducted.

10.1 General Biophysical Environment

10.1.1 Climate

Rustenburg falls within the Summer Rainfall Climatic Zone. The area is characteristically warm with erratic and variable rainfall, ranging from 450 to 750 mm per annum. The rainfall in the area is almost exclusively due to thunderstorms that occur during the summer months (October to March); whilst winter months are normally dry. Temperatures vary between the extremes of -6.0°C and 40°C , with an average of 19°C . The region is classed under the calm category whereby wind speeds are relatively low, with between 19 and 24 days of frost per year. The area is fog-free and hailstorms are a rare occurrence. The mean circulation of the atmosphere is predominantly anti-cyclonic throughout the year, except near the surface where meso-scale circulations prevail. Fine conditions and light variable winds with a northerly component occur over the region. Elevated inversions, which occur as a result of the anticyclonic subsidence, suppress the diffusion and vertical dispersion of pollutants by reducing the depth of the mixing layer. Seasonal variations in the position and the intensity of the high-pressure cells determine the extent to which the tropical easterly circulation and the circumpolar westerlies are able to impact on the atmosphere over the region. The tropical easterlies, and the occurrence of easterly waves and lows, affect the region throughout the year resulting in airflow with a north-easterly to north-westerly component, but their influence is generally weaker during the winter months. The winter weather is dominated by perturbations in the westerly circulation as a result of the succession of cold fronts moving over the region. The passage of a cold front is characterised by pronounced variations in wind direction, wind speed, temperature, humidity and surface pressure. Airflow ahead of the cold front has a distinct north-north-westerly to north-easterly component.

Following the cold front, the northerly wind is replaced by winds with a distinct southerly component. During the summer months, the anti-cyclonic belt weakens and shifts southwards, allowing the tropical easterly flow to resume its influence over the region. The predominant wind is from the southwest with greater variation during summer months (Figure 14) (Anglo, 2016).

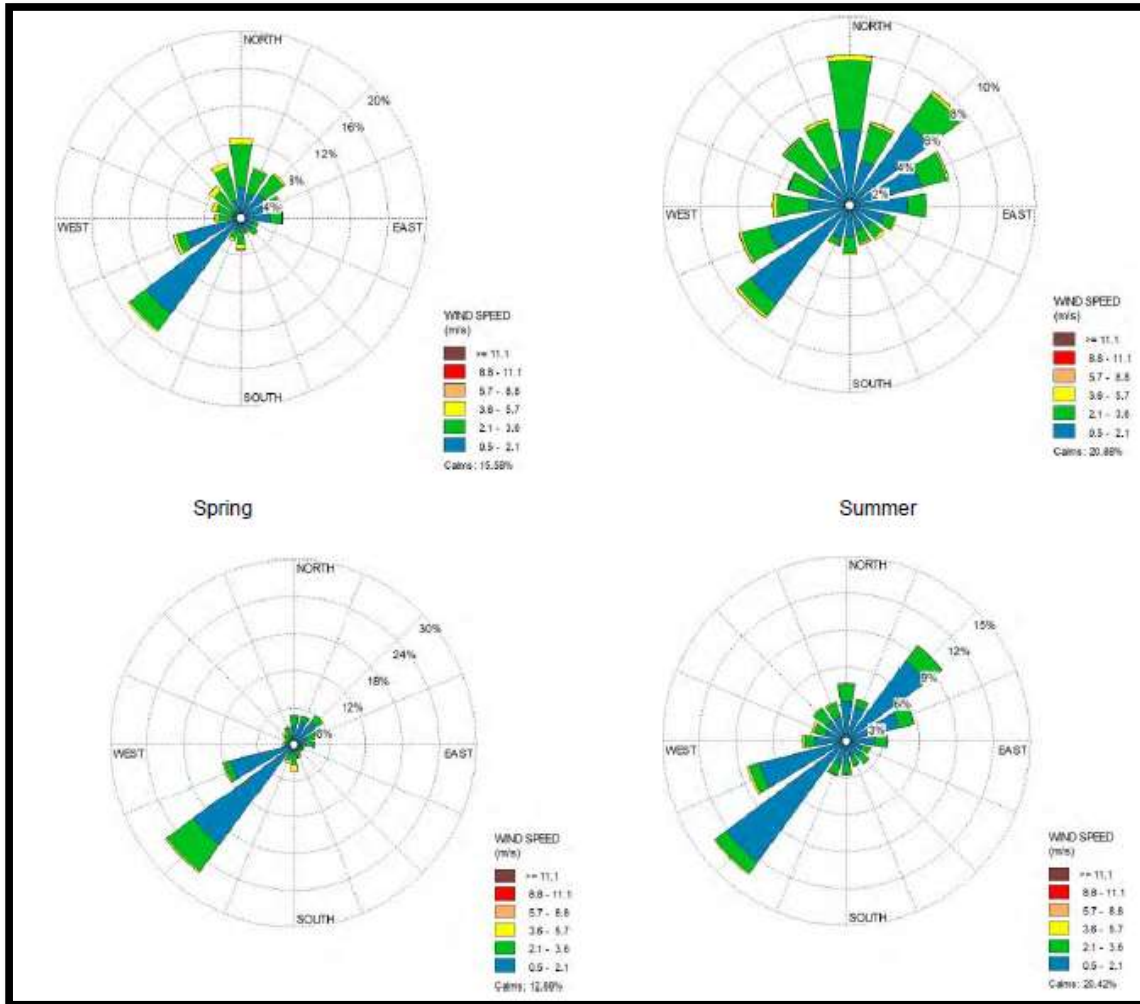

Figure 14: Wind Roses for the project area

10.1.2 Surface Hydrology

The proposed project falls in quaternary catchment A22F located within the Crocodile West Marico Water Management Area (WMA 5). Quaternary catchment A22F is drained by the perennial Leragane River flowing in a northeast direction to feed the eastward-flowing Elands River and a few of unnamed tributaries.

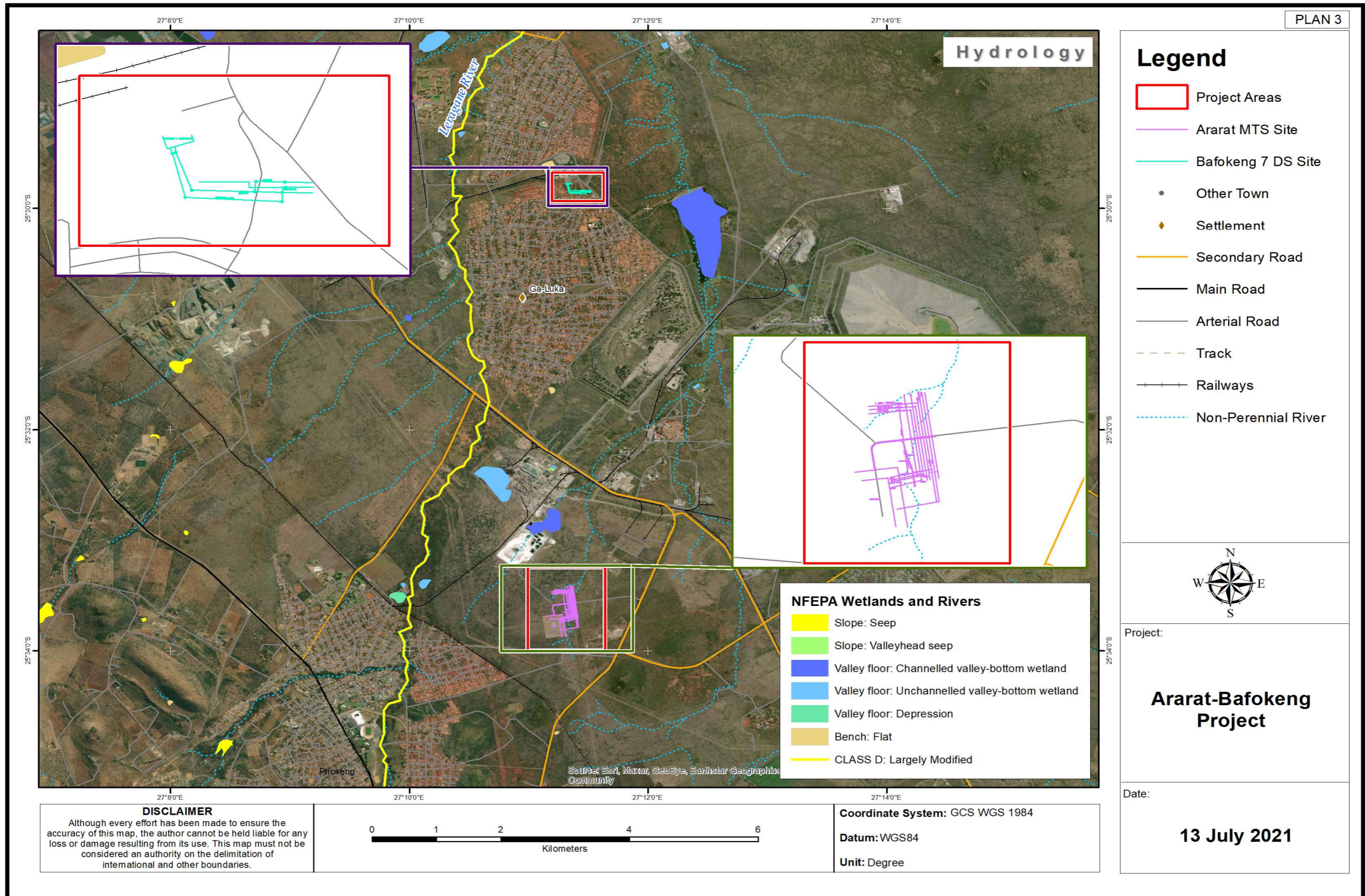

Figure 15: Hydrological Map of the study area

10.1.3 Regional Vegetation

The entire project sites fall within the Savanna Biome and this Biome is the largest Biome in South Africa and occupies over one third of the country. It is characterized by a grassy ground layer and distinct upper layer of woody plants. This biome is defined by an herbaceous layer dominated by grass species and a discontinuous to sometimes very open tree layer (Low and Rebelo, 1996).

According to Mucina and Rutherford (2018), the Ararat site falls within the Marikana Thornveld vegetation type whilst Bafokeng site falls within the Zeerust Thornveld vegetation type, as indicated in Figure 16.

10.1.4 Conservation & Protected Areas

The aim of the National Environmental Management: Protected Areas Act (Act No. 57 of 2003) is to provide for the protection and conservation of ecologically viable areas representative of South Africa's biological diversity and natural seascapes. The purpose of a Protected Environment is amongst others to protect a specific ecosystem outside a special nature reserve world heritage site or nature reserve and also to ensure the use of the natural resources in the area is sustainable.

The two proposed sites are not situated within any of the formally Protected Areas, and the closest one is approximately 10Km away from Ararat site, namely Magaliesberg Protected Natural Environment.

According to National Protected Areas Expansion Strategy (NPAES) (2008), its goal is to achieve cost-effective protected area expansion for ecological sustainability and increased resilience to climate change. It sets targets for protected area expansion, provides maps of the most important areas for protected area expansion, and makes recommendations on mechanisms for protected area expansion. The two proposed sites do not fall within any of the NPAES focus areas, the closest being the NW/Gauteng Bushveld.

The proposed sites do not fall within any recognised Critical Biodiversity area nor Ecological Support Area as shown in Figure 17 below.

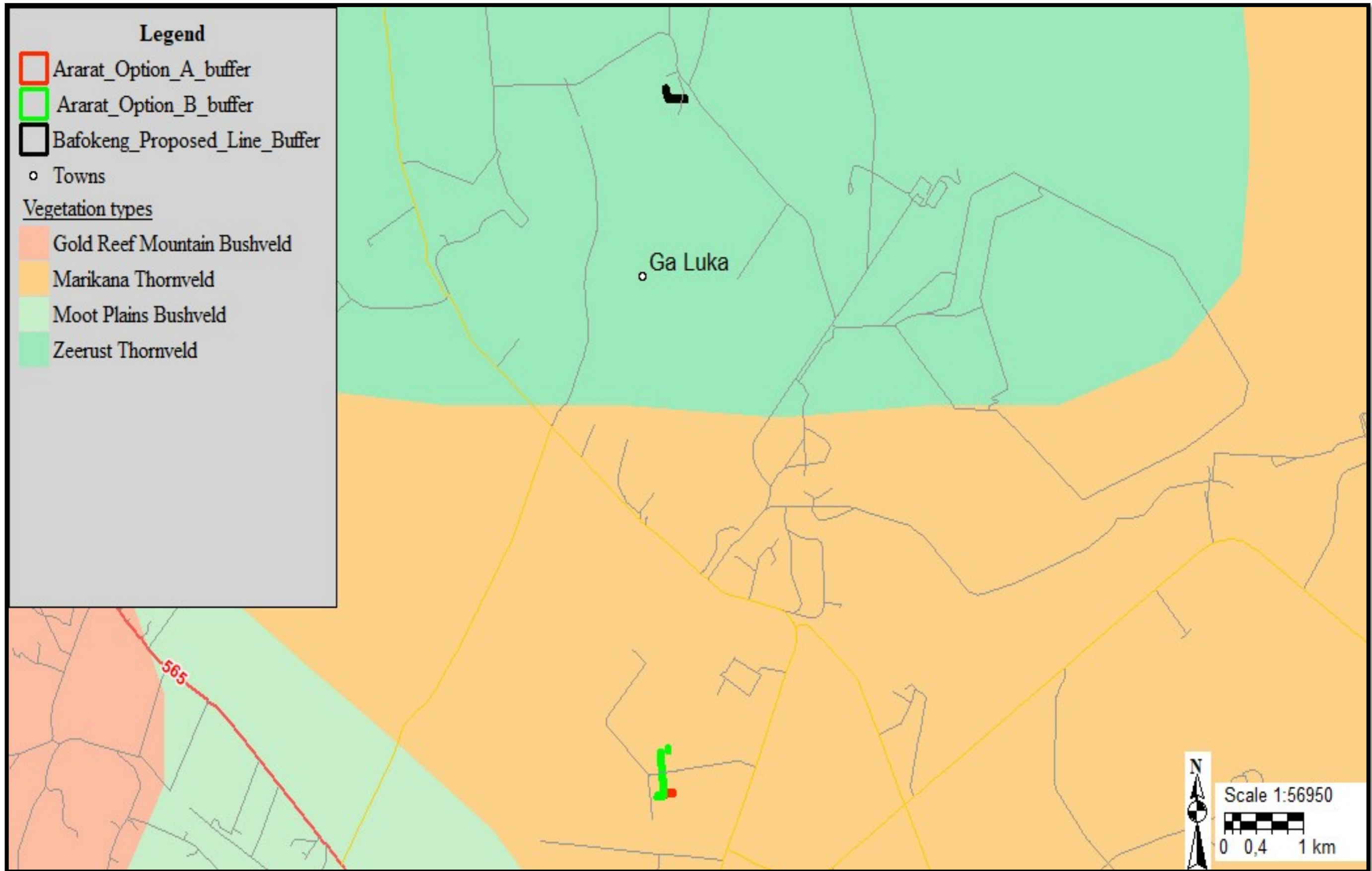

Figure 16: Regional vegetation types onsite

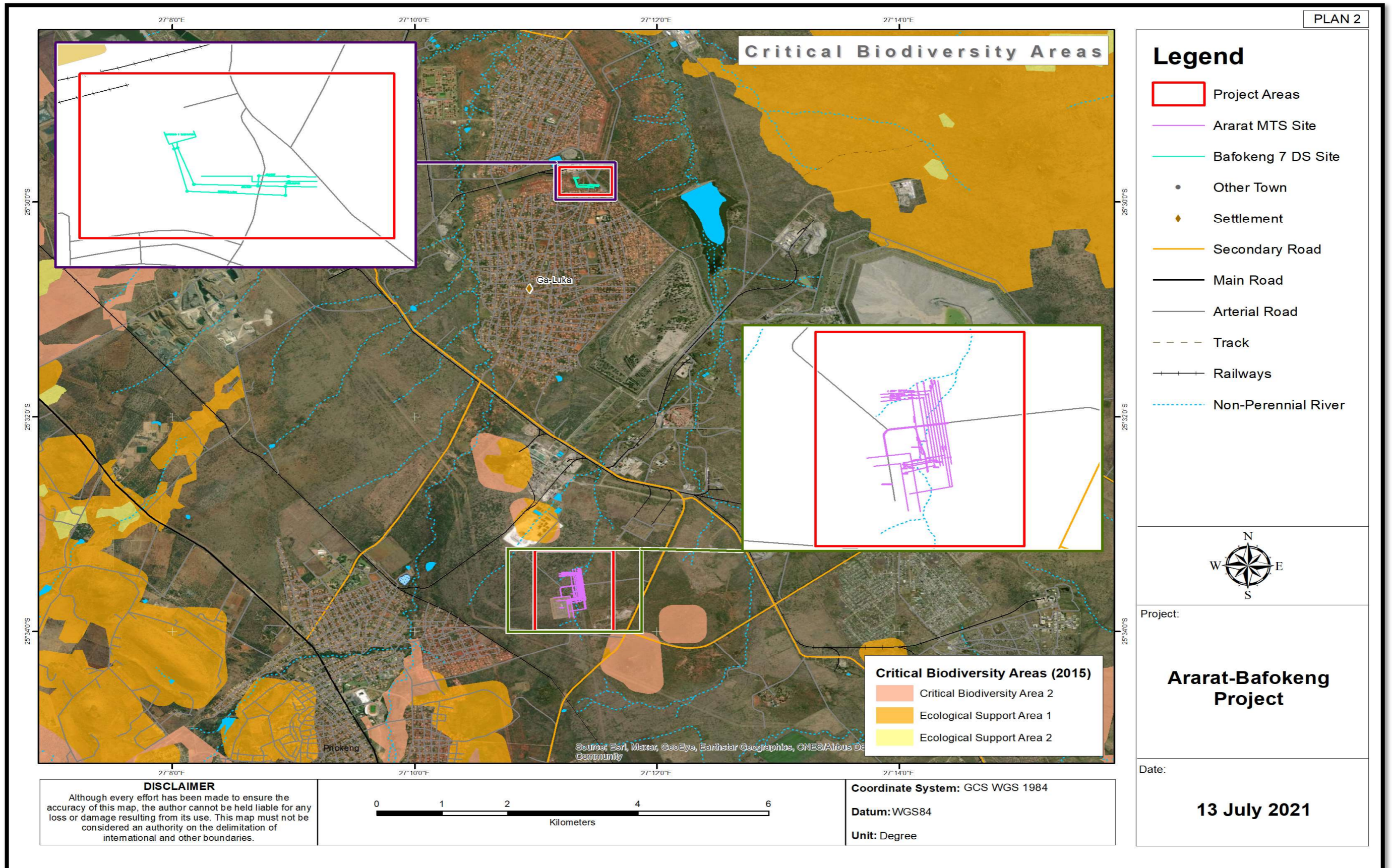

Figure 17: Map showing the proposed sites do not traverse any CBA's

10.1.5 Geology

The project area is located within one of the largest layered mafic intrusions in the world, namely the Bushveld Igneous Complex. The Bushveld Igneous Complex system is divided into an eastern and western limb with a further northern extension. It contains some of the richest ore deposits on Earth. The Bushveld Igneous Complex is extensive in size, covering an area of 65 000 km²; stretching approximately 350 km east to west and 250 km north to south. It is roughly saucer-shaped with the edges dipping inwards towards the centre. At the rim of the 'saucer', pyroxenites, norites, gabbro's and chromatids are found inter-layered in a variety of combinations (Anglo, 2016). The Bushveld Igneous Complex comprises a suite of layered ultramafic/mafic rock, up to nine (9) km thick (known as the Rustenburg Layered Suite), roofed by Rooiberg Group Felsic volcanic and granophyre's and a suite of late Bushveld granites. This layered suite is preserved in five (5) lobes: the far western, western, eastern and northern, and the south-eastern lobe. According to Cawthorne et al 1999, the Rustenburg Layered Suite, which ranges in composition from dunnite to ferro diorite, is subdivided into five (5) composite zones. Marginal Zone (this is not always present, comprises up to 880m of heterogeneous noritic rocks along the basal contact of the Bushveld Igneous Complex);

- Lower Zone (this comprises of dunnites, harzburgites and pyroxenites);
- Critical Zone (this is characterised by spectacular layering and hosts world-class chromite and platinum deposits in several reefs);
- Main Zone (this is the thickest zone, comprising of a succession of gabbro-norites in which olivine and chromite are absent and anorthosites are rare); and
- Upper Zone (this is 200m thick and is characterised by lithologies of Anorthosite, troctolite and ferro gabbro to diorite).

Unique to the Bushveld Igneous Complex is the presence of two (2) stratiform deposits, known as the Merensky reef and the UG2 reef, that can be traced for hundreds of kilometres along the rim of the deposits and contain economically exploitable quantities of PGMs. The Bushveld Igneous Complex remains Anglo American Platinum's primary source of reserves and resources (RDNW(KL) 6/2/2/195(4), 2009). PGM's are recovered from the tabular Merensky reef that is present along the entire strike length of the South-eastern parts of the Bushveld Igneous Complex. The UG2 (present only in certain pockets along the South-eastern limb) also contains economic quantities of PGM's. The Merensky reef is the predominant ore body, but the UG2 reef is also mined in certain pockets (Anglo, 2016).

10.1.6 Heritage

Research here has also helped to bridge the gap between history and archaeology. Oral traditions, early historic records and archaeology all point to a complex mix of Sotho-Tswana (Kwena) as well as Southern (Tlhako) and Northern Nguni people (Fokeng, BaPo and Tlokwa) before Europeans entered the area. Historical archaeologists are now actively researching the complexity of this ethnic mix.

In the Magaliesberg area, evidence of smelting and metal working comes mainly from three sites; Broederstroom in Pretoria, Uitkomst in Krugersdorp and; Olifantspoort in Rustenburg. The area of Magaliesberg extends from the west of the Rustenburg to the east of Pretoria in the Transvaal. This area is rich in two main resources that are needed in metal working; ore and wood. Hills and Ridges such as the Timeball Hills and Daspoort Ridges consisted of ironstone and (was) very densely wooded, which meant enough wood supply required for charcoal (Friede 1977). The remains found in the Olifantspoort settlement dated from MIA (1000AD) to LIA (1800AD). Such remains include a smelting furnace and some slag-like material. None of the Iron age material were found of the proposed site.

10.1.7. Soils and Land-Use and Land capability

The soils of the region are derived from norite which is a mafic rock, rich in basic cations. Generally, the soils are deep, dark brown to black, clayey and have a very coarse blocky or prismatic structure with distinctive slickened sides. Calcium carbonate nodules are abundant throughout the soil profile and on the soil surface. Soils in the wetter areas (along the riverbanks etc.) are generally underlain by gleied material while soils in the drier regions are abruptly underlain by norite. The dominant soil forms in the region are Arcadia and Rensburg. Shallower soils occur between rocky outcrops. These soils show less structure and are better described by the Milkwood form which comprises of the Melanic A (dark, well-structured A) horizon directly overlying unweathered rock. A study conducted by Clean Stream Environmental Services in 2015 identified a total of 5 soil units; Ar1, Ar2, Ar/R, Hu and R. The soils are classified as moderate to deep clayey loam soils. The net primary agriculture production is classified as low (4-6%). The area covered by Rustenburg Section is predominantly used for subsistence farming, in the form of ad hoc grazing of the livestock from many of the formal and informal settlements in the area. The remaining land uses consist of mining, residential and to a limited extent, conservation. It must however be noted that the land has already been changed as a result of the construction of the anthropogenic activities happening in and around the proposed project sites.

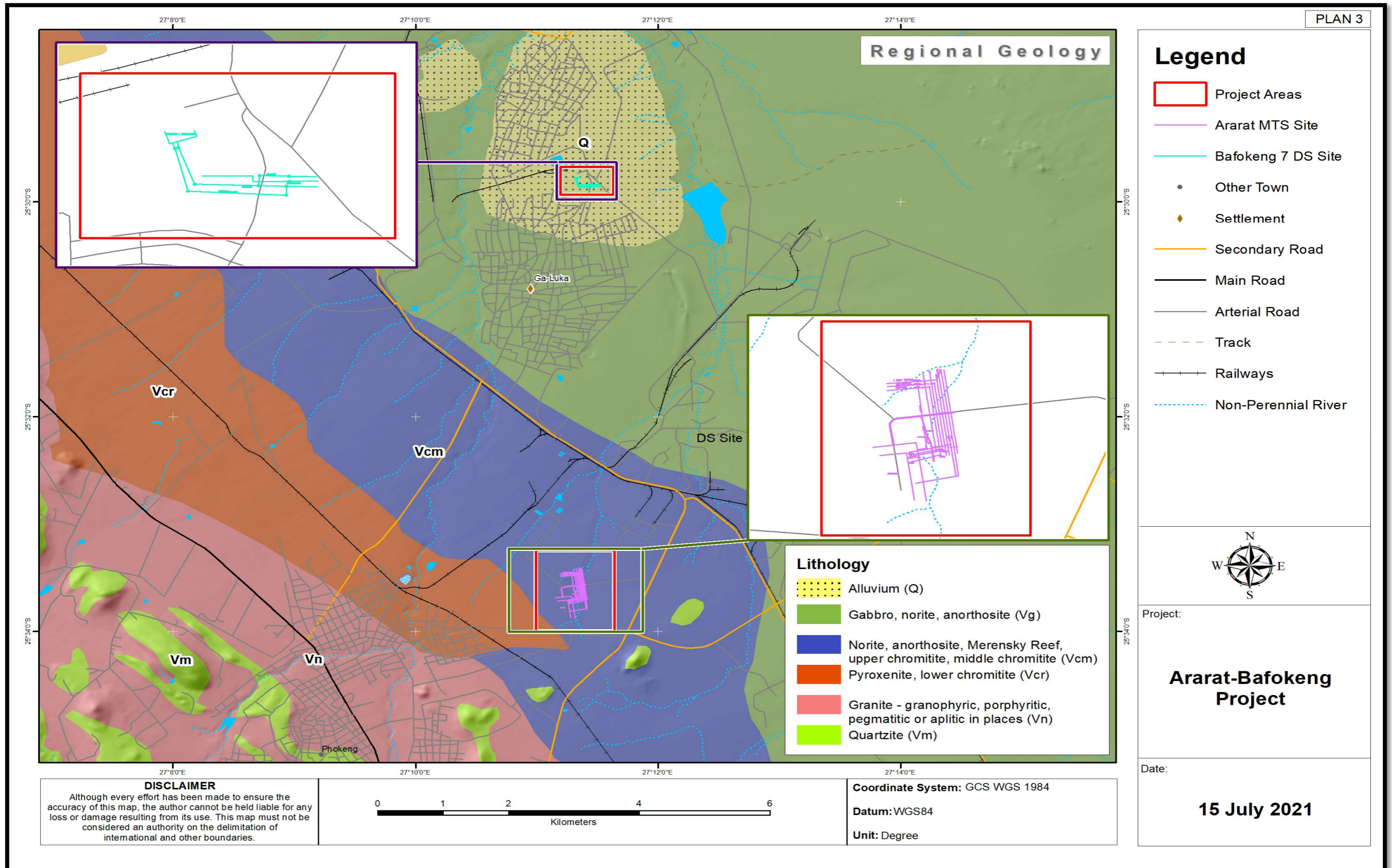

Figure 18: Geology of the study area

11. 11. IMPACT ASSESSMENT

11.1 The Impact Assessment aimed to achieve the following:

- An assessment of the environment likely to be affected by the proposed project, including cumulative environmental impacts.
- Any assessment of the environment likely to be affected by the identified alternative land use or developments, including cumulative environmental impacts (if applicable)
- An assessment of the extent, duration, intensity, probability and significance of the identified potential environmental, social and cultural impacts of the proposed development including cumulative impacts.
- A comparative assessment of the identified land use and development alternative and their potential environmental, social and cultural impacts (if applicable)
- Inclusion of technical and supporting information as appendices (if any)

11.2. Methodology of Impact Assessment

The assessment of impacts adhered to the minimum requirements in the EIA Regulations of 04th December 2014, as amended 07th April 2017 and must take applicable official guidelines into account. The issues raised by interested and affected parties must also be addressed in the assessment of impacts.

As means of determining the significance of the various impacts that were associated with the proposed development of an 88kV Ararat-Bafokeng power line, a series of assessment criteria were used for each impact. Environmental Impacts were assessed by different criteria to assign relative significance to each predicted impact associated with an activity. The criteria used to evaluate the impacts of this activity were as follows: nature, extent, duration, intensity and probability of occurrence.

- **Nature:** A brief written statement of the environmental aspect being impacted upon by a particular action or activity;
- **Scale:** The area over which the impact was expressed;
- **Duration:** The duration indicated what the lifetime of the impact was;
- **Magnitude/Severity:** Describes whether an impact is destructive or benign; and
- **Probability:** Describes the likelihood of the impact actually occurring.

- **Cumulative:** In relation to an activity, means the impact of an activity that in itself may not be significant but may become significant when added to the existing and potential impacts eventuating from similar or diverse activities or undertakings in the area.

The significance of the impacts will be determined through a synthesis of the criteria below:

Probability: This describes the likelihood of the impact actually occurring

Improbable: The possibility of the impact occurring is very low, due to the circumstances, design or experience.

Probable: There is a probability that the impact will occur to the extent that provision must be made, therefore.

Highly Probable: It is most likely that the impact will occur at some stage of the development.

Definite: The impact will take place regardless of any prevention plans and there can only be relied on migratory measures or contingency plans to contain the effect.

Duration: The lifetime of the impact

Short Term: The impact will either disappear with mitigation or will be mitigated through natural processes in a time span shorter than any of the phases.

Medium Term: The impact will last up to the end of the phases, where after it will be negated.

Long Term: The impact will last for the entire operational phase of the project but will be mitigated by direct human action or by natural processes thereafter.

Permanent: The impact is non-transitory. Mitigation either by man or natural processes will not occur in such a way or in such a time span that the impact can be considered transient.

Scale: The physical and spatial size of the impact

Local: The impacted area extends only as far as the activity, e.g., footprint

Site: The impact could affect the whole, or a measurable portion of the above-mentioned properties.

Regional: The impact could affect the area including the neighbouring residential areas.

Magnitude/ Severity: Does the impact destroy the environment, or alter its function

Low: The impact alters the affected environment in such a way that natural processes are not affected.

Medium: The affected environment is altered, but functions and processes continue in a modified way.

High: Function or process of the affected environment is disturbed to the extent where it temporarily or permanently ceases.

Significance: This is an indication of the importance of the impact in terms of both physical extent and time scale, and therefore indicates the level of mitigation required.

Negligible: The impact is non-existent or unsubstantial and is of no or little importance to any stakeholder and can be ignored.

Low: The impact is limited in extent, has low to medium intensity; whatever its probability of occurrence is, the impact will not have a material effect on the decision and is likely to require management intervention with increased costs.

Moderate: The impact is of importance to one or more stakeholders, and its intensity will be medium or high; therefore, the impact may materially affect the decision, and management intervention will be required.

High: The impact could render development options controversial or the project unacceptable if it cannot be reduced to acceptable levels; and/or the cost of management intervention will be a significant factor in mitigation.

Significance is determined through a synthesis of impact characteristics. Significance is an indication of the importance of the impact of both physical extent and time scale, and therefore indicates the level of mitigation required. The total number of points scored for each impact indicates the level of significance of the impact.

Significance is derived using the following formula:

$$\text{Significance} = (\text{Scale} + \text{Duration} + \text{Magnitude/Severity}) \times \text{Probability}$$

Table 7: Significance Ratings

Aspect	Description	Weight
Probability	Improbable	1
	Probable	2
	Highly Probable	4
	Definite	5
Duration	Short term	1
	Medium term	3
	Long term	4
	Permanent	5
Scale	Local	1

	Site	2
	Regional	3
Magnitude/Severity	Low	2
	Medium	6
	High	8
Significance	Sum (Duration, Scale, Magnitude) x Probability	
	Negligible	≤20
	Low	>20 ≤40
	Moderate	>40 ≤60
	High	>60

Cumulative Effects: It is important to assess the natural environment using a systems approach that will consider the cumulative impact of the various actions. A cumulative impact refers to the impact on the environment, which results from the incremental impact of the actions when added to other past, present and reasonably foreseeable future actions regardless of what agencies or persons undertake such actions. Cumulative impacts can result from individually minor but collectively significant actions or activities taking place over a period of time. Cumulative impacts can take place so frequently in time that the effects cannot be assimilated by the environment.

Identification of Mitigation Measures: The mitigation measures should describe possible actions for the mitigation of the significant negative environmental impacts identified in the assessment. The philosophy of identifying mitigation measures for negative impacts will be based on the reduction of the impact at source, the management of the impact through monitoring and control, and the involvement of the I&APs in consideration of mitigating measures, where appropriate.

Maximisation of Positive Impacts: The philosophy to be followed will focus on maximizing the benefits to the local environment.

Status	Denotes the perceived effect of the impact on the affected area
Positive(+)	Beneficial impact.
Negative (-)	Deleterious or adverse impact.
Neutral (/)	Impact is neither beneficial nor adverse.

Table 8: Planning and Design Phase Impacts

Potential or Impact	Aspect	Before Mitigation				Significance rating	Mitigation Measures	After Mitigation				Significance Rating
		S	D	M	P			S	D	M	P	
Planning and Creating Environmental Awareness		3	4	6	5	-65 High	<ul style="list-style-type: none"> Appointment of ECO and other role players, i.e., site manager, Environmental Officer (EO), Contractor's manager and Community Liaison Officer All role-players must understand their part in the implementation of the mitigation contained in this BAR and in the EMPr Required method statements are compiled and approved. Ensure environmental awareness among their employees and sub-contractors so that they are fully aware of, and understand the Environmental Specifications and the need for them All identified protected tree species must be marked within the project footprint. Establish procedures to effectively verify and address complaints and claims received Complaints or liaisons with landowners with regard to environmental matters must be recorded, reported to the correct person and a record of the response is to be entered in the complaints register Establish lines of communications with landowners. Provide relevant contact details to landowners for queries / raising of issues or complaints Landowners will be kept up to date with projected construction durations on their properties Include environmental awareness aspects into the site induction program to ensure all staff is aware of the location and importance of watercourses on site. The Contractor shall ensure that all site personnel have a basic level of environmental awareness training and that training manual 	3	3	2	5	+40 Low

Potential or Impact	Aspect				Significance rating	Mitigation Measures	After Mitigation				Significance Rating
	S	D	M	P			S	D	M	P	
						<ul style="list-style-type: none"> and toolbox talk topics cover issues such as; <ul style="list-style-type: none"> ➤ What is meant by “Environment”? ➤ Why the environment needs to be protected and conserved etc. • Use must be made of environmental awareness posters on site. • The need for a “clean site” policy also needs to be explained to the workers. 					
Site preparation	3	3	6	5	-60 Moderate	<ul style="list-style-type: none"> • The working width of the construction area must be clearly demarcated prior to construction. Soil and vegetation to be stripped only from project footprint area. No-go areas particularly sensitive areas (e.g., river or drainage lines) are to be demarcated or spanned over. • If the construction camp is required in the study area, the contractor must establish a construction camp in an area as agreed with the ECO. The site for the construction camp must not be in an environmentally sensitive area such as in close proximity to a watercourse or on a steep slope. • The use of roads on landowner property must be determined based on discussions with landowners during the servitude negotiation process. Letters of agreement with landowners must be kept on a file. • All identified protected tree species must be marked within the project footprint. All employees must be educated on identifying protected tree species. • Workers must be educated to recognize markers on plants. Sensitive environmental features must be identified, mapped and demarcated as no go areas 	3	3	2	4	+32 Low
Method statements	3	4	6	4	+52 Moderate	<ul style="list-style-type: none"> • Contractor shall not commence work on that activity until such time as the Method Statement has been approved in writing by the developer ECO. 	3	3	2	4	-32 Low

Potential or Impact	Aspect	Before Mitigation				Significance rating	Mitigation Measures	After Mitigation				Significance Rating
		S	D	M	P			S	D	M	P	
							<ul style="list-style-type: none"> The Contractor shall carry out the activities in accordance with the approved Construction Method Statements. Approved Method Statements shall be readily available on the site and shall be communicated to all relevant personnel. Approval of the Method Statement shall not absolve the Contractor from any of his obligations or responsibilities in terms of the EMP specifications. Activities that will require method statements include, but not limited to: <ul style="list-style-type: none"> Dust Control Vegetation removal The storage provisions for construction material and/or equipment 					
Environmental incidents		2	1	6	8	-72 High	<ul style="list-style-type: none"> The contractor must take corrective action to mitigate an incident appropriate to the nature and scale of the incident and must also rehabilitate any residual environmental damage caused by the incident or by the mitigation measures themselves. All incidents must be reported to the ECO and the developer. 	2	1	6	2	+18 Negligible

Table 9: Construction Phase Impacts

Potential Aspect or Impacts	Before Mitigation				Significance rating	Mitigation Measures	After Mitigation				Significance Rating
	S	D	M	P			S	D	M	P	
Excavation for tower installation poles	2	1	6	5	-45 Moderate	<ul style="list-style-type: none"> All excavation (if not working in the area) must be barricaded or covered to prevent safety and environmental accidents. Minimise the time taken to complete each operation that is causing inconvenience or disruption in this area. Make temporary access ways over any excavations. To inform property owners of the exact time and duration of closing entrances to any properties at any one time. 	2	1	2	5	+25 Low
Erosion Control	2	1	6	4	-36 Low	<ul style="list-style-type: none"> The Contractor is to provide a method statement on how erosion control will be managed on site during construction and rehabilitation. Areas where erosion is likely (e.g., steep slopes [gradient > 6%], areas cleared of topsoil and topsoil stockpiles) must be monitored. Erosion control structures i.e., earth embankments must be put in place where soil may be exposed to high levels of erosion due to steep slopes, soil structure etc. All construction areas must be suitably top soiled and vegetated as soon as is possible after construction. 	2	1	2	2	+10 Negligible
Stockpiling soil	2	3	6	5	-55 Moderate	<ul style="list-style-type: none"> Ensure that excavated and stockpiled soil material is stored and bermed on the higher lying areas of the site and not in any storm water run-off channels or any other areas where it is likely to cause erosion or where water would naturally accumulate. The areas where excavated soil will be stockpiled must be bordered by berms to prevent soil loss caused by rain. 	2	1	6	5	+45 Moderate

Potential Aspect or Impacts	Before Mitigation				Significance rating	Mitigation Measures	After Mitigation				Significance Rating
	S	D	M	P			S	D	M	P	
Sedimentation and Compaction of watercourse soils	2	3	6	4	-44 Moderate	<ul style="list-style-type: none"> The design of the pylons/towers/poles must make provision for limiting sediment build up. Reduce clearing to a minimum to maintain vegetation cover In areas where vegetation clearing is required, surface water velocity must be dissipated using sufficient drains at appropriate intervals. No stockpiles or construction materials will be stored or placed within any drainage line on site or areas where water naturally accumulates. Any stockpile stored for long periods must be retained in a bunded area. Topsoil stockpiles especially, must be covered during excessively windy conditions to preserve biodiversity functionality. Create a channel for runoff to avoid numerous runoff channels that erode the soil; No large scale of mixing of cement must be done within the drainage lines. Where possible, ready-mix cement must be used for the structures to be constructed. All mixing of cement must occur on top of an impermeable surface. Re-vegetate cleared soil after construction for the control of soil erosion and water capacity. Avoid driving on watercourses during construction of the distribution line to prevent vehicle track incision and the potential for channel initiation. Where this is unavoidable crossing structures must be in place across affected watercourses. 	2	1	2	2	+10 Negligible
Air Quality	2	3	6	4	-44 Moderate	<ul style="list-style-type: none"> Vehicles transporting friable materials such as sand, Gravel etc. must be covered with a tarpaulin, and their speed must be limited to 40km/hr. All construction vehicles must be in good working order to prevent unnecessary exhaust fumes. Dust suppression mechanisms must be employed in areas of high vehicle movement. 	2	1	2	2	+10 Negligible
Noise Pollution	1	3	6	4	-40	<ul style="list-style-type: none"> The construction phase must aim to adhere to the relevant noise 	1	1	2	4	+16

Potential Aspect or Impacts	Before Mitigation				Significance rating	Mitigation Measures	After Mitigation				Significance Rating
	S	D	M	P			S	D	M	P	
					Low	<p>regulations and limit noise to within standard working hours in order to reduce disturbance of habitable areas in close proximity to the development.</p> <ul style="list-style-type: none"> Construction site yards, workshops, and other noisy fixed facilities must be located well away from noise sensitive areas. Once the proposed final layouts are made available by the contractor(s), the sites must be evaluated in detail and specific measures designed into the system. Truck traffic must be routed away from noise sensitive areas, where possible. Noisy operations must be combined so that they occur where possible at the same time. Blasting operations (if required) are to be strictly controlled with regard to the size of explosive charge in order to minimise noise and air blast, and timings of explosions. No blasting must be allowed at night. Construction activities are to be contained to reasonable hours during the day and early Evening. Night-time activities near noise sensitive areas must not be allowed. With regard to unavoidable very noisy construction activities in the vicinity of noise sensitive areas, the contractor and ECO must liaise with neighbours. As construction workers operate in a very noisy environment, it must be ensured that their working conditions comply with the Requirements of the Occupational Health and Safety Act (Act 85 of 1993) and the contractor must take measures to discourage labourers from loitering in the area and causing noise disturbance. Where possible labour shall be transported to and from the site by the contractor or his Sub-Contractors by the contractors' own transport. 					Negligible
Visual	1	4	8	4	-52 Moderate	<ul style="list-style-type: none"> Colour/Coating: Using a coating on the steel that is darker than galvanized steel will reduce the visual impact. 	1	4	6	4	+44 Moderate

Potential Aspect or Impacts	Before Mitigation				Significance rating	Mitigation Measures	After Mitigation				Significance Rating
	S	D	M	P			S	D	M	P	
						<ul style="list-style-type: none"> Advertising on site must be in accordance with South African Manual for Outdoor Advertising Control (SAMOAC). The construction camp must be contained to prevent any visual intrusion and be kept in a clean and orderly state at all times. 					
Surface and Groundwater quality (Watercourses)	2	3	6	4	-44 Moderate	<ul style="list-style-type: none"> Mark watercourse areas with 'No-Go' signage. Avoid impacts on the watercourses by limiting construction/excavation activities to as small an area as possible. All daily activities that could involve the generation of waste must be restricted to the construction site and away from any watercourse. Establish emergency response measures and a clearly defined chain of communication to rapidly deal with any unforeseen impacts to the watercourses, e.g., spills. 	2	1	2	2	+30 Low
Dust	2	3	6	4	-44 Moderate	<ul style="list-style-type: none"> Dust production must be controlled by regular watering of roads and works area, should the need arise. 	2	1	2	2	+10 Negligible
Waste: Solid	2	3	6	5	-55 Moderate	<ul style="list-style-type: none"> All daily activities that could involve the generation of waste must be restricted to the construction site and away from any watercourse. Construction rubble shall be disposed of in pre – agreed, demarcated spoil dumps that have been approved by the Relevant Municipality. Littering by the employees of the Contractor shall not be allowed under any circumstances. The ECO shall monitor the neatness of the work sites as well as the Contractor campsite. All waste must be removed from the site and transported to a suitably permitted landfill site 	2	3	2	4	+28 Low
Waste: Effluent	2	3	2	5	-35 Low	<ul style="list-style-type: none"> Pollution of ground and surface water must be avoided. Mobile Ablution facilities must be available to all workers at ratio of 1:10 for females and males respectively and there must be at least one mobile toilet every 100 m. Project workers are not to use watercourses for washing or bathing. Mobile toilets shall be secured to prevent them blowing over during periods of high winds. No human waste will be allowed to enter any water courses or 	2	3	2	4	+28 Low

Potential Aspect or Impacts	Before Mitigation				Significance rating	Mitigation Measures	After Mitigation				Significance Rating
	S	D	M	P			S	D	M	P	
						<ul style="list-style-type: none"> natural drainage lines. Mobile toilets must be emptied at regular intervals by suitably qualified contractors, according to appropriate health and safety standards and the waste must be disposed of at a registered municipal waste facility. 					
Hazardous Materials	2	3	2	4	-28 Low	<ul style="list-style-type: none"> If potentially hazardous substances are to be stored on site, the Contractor shall provide a Method Statement detailing the substances/materials to be used together with the procedures for the storage, handling and disposal of the materials in a manner which will reduce the risk of pollution that may occur. All waste hazardous materials must be carefully stored as advised by the ECO, and then disposed of offsite at a licensed landfill site. Contaminants to be stored safely to avoid spillage. Machinery must be properly maintained to keep oil leaks in check. 					+14 Negligible
Stormwater Management					-45 Moderate	<ul style="list-style-type: none"> The Contractor is to provide a method statement on how stormwater will be managed on site during construction and rehabilitation. Adequate Stormwater Management must be implemented as part of the proposed activity to prevent erosion and sedimentation of the surrounding watercourses and drainage lines 					+18 Negligible
Loss of Important mainly Riparian woodland	1	3	8	4	-48 Moderate	<ul style="list-style-type: none"> No pylons, construction camps or quarries must be constructed within watercourses and headwater drainage lines) 	1	3	6	4	+40 Low
Loss of Threatened/near threatened /protected taxa	1	4	8	4	-52 Moderate	<ul style="list-style-type: none"> Although no species of concern were recorded, there however still is a low probability of occurrence 	1	4	6	2	+22 Low
Disturbance	1	3	8	4	-48 Moderate	<ul style="list-style-type: none"> The construction sites must be confined to disturbed areas or those identified with low conservation importance. 	1	3	6	4	+40 Low
Faunal, avifaunal and Floral Species					-70 High	<ul style="list-style-type: none"> Workforce to be instructed that no animals or birds may be caught or killed. 					+55 Moderate

Potential Aspect or Impacts	Before Mitigation				Significance rating	Mitigation Measures	After Mitigation				Significance Rating
	S	D	M	P			S	D	M	P	
						<ul style="list-style-type: none"> All road networks must be planned with care to minimize dissection or fragmentation of important avifaunal habitat type. 					
Hunting/ Snaring/ Poaching	1	4	6	2	-22 Low	<ul style="list-style-type: none"> Hunting/snaring is strictly prohibited. Any person found hunting or in the possession of any indigenous animal (including invertebrate taxa) must face disciplinary measures, following the possible dismissal from the site. 	1	3	6	2	+20 Negligible
Heritage and Palaeontological Resources	2	5	6	4	-52 Moderate	<ul style="list-style-type: none"> During the construction phase, the contractor must ensure adherence to the chance find protocols as defined by the Heritage, Palaeontological and EMP reports. See Section 8 (Pg. 14) of the Palaeontological Report. 	2	5	2	4	+36 Low

Table 10: Operational Phase Impacts

Potential Aspect or Impact	Before Mitigation				Significance rating	Mitigation Measures	After Mitigation				Significance Rating
	S	D	M	P			S	D	M	P	
Maintenance Of servitude (fire/clearing/ composition shifts)	2	4	6	2	-24 Low	<ul style="list-style-type: none"> Open fires are strictly prohibited and only allowed at designated areas 	2	4	2	2	+16 Negligible
Hunting/ Snaring/ Poaching	1	4	6	2	-22 Low	<ul style="list-style-type: none"> Hunting/snaring is strictly prohibited. Any person found hunting or in the possession of any indigenous animal (including invertebrate taxa) must face disciplinary measures, following the possible dismissal from the site. 	1	3	6	2	+20 Negligible
Proliferation Of alien plant species	2	4	8	2	-28 Low	<ul style="list-style-type: none"> Vegetation pruning, erosion, colonisation of area by alien species, etc. are monitored and inspected as an on-going process in line with the EMPr Compile and implement an alien plant control program during the operational phase of the project. Declared alien vegetation must be controlled and the spread thereof proactively managed 	1	3	6	2	+20 Negligible
Electrocution	2	5	8	4	-60 Moderate	<ul style="list-style-type: none"> It is recommended from an avifaunal perspective a "bird friendly" pylon design be used which poses little electrocution risk. 	2	4	8	2	+28 Low
Collision	1	5	8	5	-70 High	<ul style="list-style-type: none"> Sections of the line in close proximity to watercourses and drainage lines, including proximal areas of arable land and pastures be fitted with anti-collision devices 	1	4	5	4	+44 Moderate
Loss of Habitat and Disturbance					-52 Moderate	<ul style="list-style-type: none"> Many of the bird species will temporarily vacate the area during the construction phase 					+22 Low

Potential Aspect or Impact	Before Mitigation				Significance rating	Mitigation Measures	After Mitigation				Significance Rating
	S	D	M	P			S	D	M	P	
Power line maintenance	2	4	6	4	-48 Moderate	<ul style="list-style-type: none"> Regular inspection of the power line must take place to monitor its operational status. Access to the power line servitude must be restricted. 	2	1	2	4	+20 Negligible

Table 11: Decommissioning Phase Impacts

Potential Aspect or Impact	Before Mitigation				Significance rating	Mitigation Measures	After Mitigation				Significance Rating
	S	D	M	P			S	D	M	P	
Rehabilitation of Vegetation	2	4	6	4	+48 Moderate	<ul style="list-style-type: none"> Vegetation cover is to be established as quickly as possible after completion of construction. Topsoil removed during the construction phase must be used where possible to rehabilitate disturbed areas; Topsoil must be analysed for its fertility and if reduced, appropriate fertilisers must be used to increase the fertility of the soil prior to rehabilitation. Re-vegetate the area with plant species consistent to surrounding environment, i.e., local vegetation. Methods and timing of rehabilitation must be prescribed by an ecologist based on site conditions at the time under the guidance of the ECO. Badly damaged areas must be fenced off to allow the area to rehabilitate. Remove invasive vegetation from damaged construction area and from rehabilitated areas Manual labour to be used to remove alien plant species instead of chemical removal 	2	3	6	4	+44 Moderate
Dismantling power line	1	3	6	4	+40 Low	<ul style="list-style-type: none"> All scrap metals must be taken to Eskom stores. Other materials must be disposed accordingly by ESKOM 	1	3	6	5	+20 Negligible

12. POTENTIAL CUMULATIVE IMPACTS

GN 982 defines a cumulative impact in relation to an activity as *“the past, current or reasonably foreseeable future impact of an activity, considered together with the impact of activities associated with that activity, that in itself may not be significant, but may become significant when added to the existing and reasonably foreseeable impacts eventuating from similar or diverse activities”*. Cumulative impacts imply the sum total or combined impacts (positive and negative) associated with the proposed development whether on a local or regional scale.

This section provides cumulative impacts ratings associated with the proposed project which include infrastructure development, Livestock Farming activities and Ecological Resources. It outlines the significance of the impact with and without mitigation measures. Cumulative impacts were assessed having taken cognizance of the following;

- a. The proposed Ararat Alternative Route A, Ararat Alternative Route B and the Bafokeng 7 Route are all proposed within areas that have a number of existing lines. As such, the impacts that are already in the area will be enhanced to a degree, pre-mitigation. The effect would be to have impacts cumulating along these route alignments. Associated impacts (negative and positive) would include;
 - Impacts on the flora, fauna and avifauna along the proposed routes such as encroachment of alien vegetation after local and or indigenous vegetation has been cleared and the possible increase in the mortality rates of avi-fauna due to the addition of powerlines,
 - Socio-economic impacts, e.g., reduction in land value, due to the further fragmentation of land parcels and land sterilization due to the acquisition of servitudes and increase in the rate of disease after the contractor’s workforce has left the locality;
 - The further use of already existing access roads and construction of construction camps during construction and further use of already existing access roads during maintenance; and
 - The permanent visual intrusion that will be caused by the powerlines.

12.1 Impacts on the Infrastructure Development

Any housing and other infrastructure development projects planned by municipalities, communities or landowners near or within the powerline servitudes will potentially be affected by the proposed powerline project. All the proposed infrastructure developments within the study area were taken into consideration during the Impact Assessment to determine the most viable route for the proposed new powerlines. The potential cumulative impacts on the ground were found to be low to negligible as the location of the Bafokeng 7 route and the Ararat Route Alternatives fall outside any reasonable prospect of development owing mostly to their location and feasibility.

Table 12: Table of Impact for Infrastructure Development

Aspect	Mitigation Status	Probability	Duration	Extent	Magnitude Severity	Significance
Infrastructure Development	Without Mitigation	2	5	1	6	24
	With Mitigation	2	5	1	2	16

12.2 Impacts on Ecological Resources

The cumulative impact of constructing the proposed 88kv power lines parallel to existing power lines within already defined ecological corridors, would cause further habitat fragmentation and a minor degree of habitat degradation as the affected ecosystems are not sensitive ecosystems. The cumulative impact of the proposed powerlines is high to moderate over time due to the inevitable loss of vegetation. The risk of bird collisions and electrocutions will increase in time, however, should also decline as the avi-fauna adapt to the presence of the new structures. Electrocution is more common in large-bodied bird species in the area which were not identified to be present.

- Land clearing activities and other construction-related disturbances could lead to the proliferation of exotic vegetation;
- Displacement of sensitive avifaunal species, species of conservation concern and protected trees due to habitat destruction and habitat fragmentation eventually leads to isolation and loss of those species. This is, however, considered to be low within the region;
- Destruction of nesting habitat displaces the affected species eventually leading to loss of those species;
- Cumulative loss of primary vegetation features due to exotic vegetation and vegetation transformation is high at the national level and therefore should be avoided;
- Encroachment of alien vegetation; and
- Powerlines represent the largest proportion of established aerial infrastructure throughout the country and collision impacts are of national concern. Fitment of devices on the earth wires to make the lines more visible is reducing this impact at the national level.

Table 13: Table of Impact for Ecological Resources

Aspect	Mitigation Status	Probability	Duration	Extent	Magnitude Severity	Significance
Ecological Resources	Without Mitigation	5	3	2	8	65
	With Mitigation	5	2	2	6	50

12.4 Socio-economic Impacts

Construction activities associated with the project and future planned powerlines will attract "job-seeking" people to the area, which could result in subsequent "urban sprawl" to Ga Luka and Mogono. "Job-seeking" opportunities near the substations could also result in the localised depletion of natural resources and direct persecution of bird/animal taxa.

With the influx of jobseekers, comes the unwanted predatory behaviour like crime and increased sexual activity in communities resulting in the spread of diseases such as HIV/Aids and the proliferation of crime. If left unabated, the socio-economic consequences could result in cumulative health and security concerns over time. When mitigation measures are applied however, cumulatively, the potential impacts range from high to low.

Table 14: Table of Impact for Socio-economic Activities

Aspect	Mitigation Status	Probability	Duration	Extent	Magnitude Severity	Significance
Socio-economic Impacts	Without Mitigation	5	4	2	6	60
	With Mitigation	1	3	1	2	6

13. IMPACT ASSESSMENT AND SUMMARY

An **Environmental Impact Statement (EIS)** is an assessment of the likely influence a project may have on the environment. "Environmental Impact Assessment can be defined as: The process of identifying, predicting, evaluating and mitigating the biophysical, social, and other relevant effects of development proposals prior to major decisions being taken and commitments made" (IAIA 1999). The purpose of the assessment is to ensure that decision-makers consider environmental impacts before deciding whether to proceed with new projects and what necessary precautions need to be taken into account.

During the impact assessment, potential impacts were assessed for the Construction, Operation and Decommissioning of the proposed 88kV Ararat-Bafokeng power line. Impacts of the activities are likely to have more negative, or a high to medium significance before mitigation measures are implemented.

Table 15: Impact Summary Table

IMPACT/ACTIVITY	SIGNIFICANCE	
	Before Mitigation	After Mitigation
Planning and Creating Environmental Awareness	-65	+40
Site Preparation	-60	+32
Method Statements	+52	-32
Environmental Incidents	-72	+18
Excavation for tower footprint	-45	+25
Erosion control	-36	+10
Stockpiling soil	-55	+45
Sedimentation and Compaction of watercourse soils	-44	+10
Air Quality	-44	+10
Noise Pollution	-40	+16
Visual	-52	+44
Surface and Groundwater quality (Watercourse)	-44	+30
Dust	-44	+10
Waste: Solid	-55	+28
Waste: Effluent	-35	+28
Hazardous Materials	-28	+14
Stormwater Management	-45	+18
Loss of Important mainly Riparian woodland	-48	+40
Loss of Threatened/near threatened/protected taxa	-52	+44
Disturbance	-48	+40
Faunal, avifaunal And Floral Species	-70	+55
Hunting/Snaring/Poaching	-22	+20
Maintenance of servitude (fire/clearing/composition shifts)	-24	+16
Proliferation of alien plant species	-28	+20
Electrocution	-60	+28
Collision	-70	+44
Loss of Habitat and Disturbance	-52	+22
Power line maintenance	-48	+20
Impact of construction camp on members of the local community	-52	+22
Visual impact of the powerline	-40	Cannot be fully managed or mitigated

IMPACT/ACTIVITY	SIGNIFICANCE	
Rehabilitation of Vegetation	+48	+44
Dismantling power line	+40	+20

14. ENVIRONMENTAL MANAGEMENT PROGRAMME REPORT

The EMPr outlines all activities that have to be undertaken, where they will take place, the responsible persons, all possible environmental or social impacts, mitigation measures, rehabilitation plans, monitoring methods, the frequency of monitoring and performance indicators. The EMPr is a legally binding stand-alone document, which will be used to ensure that ESKOM adheres to all conditions of the Environmental Authorisation (EA) and Basic Assessment Report (BAR).

15. SPECIALIST RISK MATRIX

The results of specialist study were used by the Environmental Assessment Practitioner to create an integrated assessment of the proposed development. The outcomes of the integration and assessment are documented in this Final Basic Assessment Report. Following the public participation comment period, comments will be consolidated and this report will be updated for submission to the Competent authority.

Table 16: Specialists Option Matrix Table

Specialist Study	Ararat Route Option A	Ararat Route Option B	Reasoning
Ecological Study	X	O	Ararat Route Option A was preferred as it is a shorter route therefore less vegetation will be removed
Heritage Study	Y	Y	Equal reference due to the absence of Heritage resources that could be impacted upon
Palaeontological Study	Y	Y	Equal reference due to the absence of Palaeontological resources that could be impacted upon
Hydrological Study	Y	Y	Equal reference due to the absence of Hydrological resources that could be impacted upon
Technical	O	X	Reduces the number of electrical cable crossings and reduced probability of multiple line failures.

X means preferred option; O means not preferred option; Y denotes equal preference

16. CONCLUSION AND RECOMMENDATION

16.1. Reasoned opinion why the project must go ahead

After the application of an impact assessment, the proposed project does not seem to have any detrimental impacts on the natural and the socio-economic environments after the application of the aforementioned mitigation measures. The study followed process as dictated by the requirements of the NEMA and

associated regulations. The proposed routes have been under detailed assessment; the primary objective being to assess the suitability of the proposed study area for the intended use from an environmental, social and economic perspective. This thorough investigation was furthermore enhanced by input from specialists.

No fatal flaws were identified during the assessment. The key issues identified during the Basic assessment were investigated further by specialist studies. The following is therefore recommended:

- Compliance with the recommendations set out in the specialist reports;
- Compliance with the Environmental Management Programme Report; and
- Consideration should be given to technical considerations as presented by ESKOM.

The findings of the investigations from specialists' input and findings of the EAP have been comprehensively documented in this report together with the specified recommendation. Based on the investigations, no fatal flaws or highly significant impacts that would impede the proposed development or necessitate redesign or termination of the project have been identified. Based on the reasons highlighted above, it is recommended that the **100m wide corridors for Alternative Ararat Route Option B and the Bafokeng 7 Route** be approved and all management and mitigation measure put in place by the developer to reduce the environmental, social and economic impacts. Alternative Ararat Route Option B has been selected due to the technical constraints as presented by ESKOM and the subsequent socio-economic impacts Alternative Ararat Route Option A could have with the high possibility of multiple line failures.

The no-go alternative was assessed and consideration of this option will have even greater social consequences particularly if the security of electricity supply is compromised to Impala Platinum's operations. Therefore, given the various development, both industrial and residential taking place across the Northwest Province, the need to secure a dependable electricity supply is of regional importance considering the knock-on effects of security of employment and as such, the no-go option is justifiably dismissed.

It is recommended by the EAP that the proposed **100m wide corridors for Alternative Ararat Route Option B and the Bafokeng 7 Route** project should be authorised, on the Condition that the environmental and social management commitments included in this BAR/EMPr are adhered to, the project description remains as per the description provided in this document and considering the positive social impacts associated with the project.

16.2. Environmental Impact Statement

This BAR serves to primarily assess the likely impacts the development may have on the surrounding environment and to provide recommendations regarding available alternatives, mitigation and management measures. The process aims to ensure that impacts are identified and where negative impacts are

anticipated that these are prevented, minimised and remedied (unless the impacts are unavoidable like visual impacts) and where positive impacts are identified that these are enhanced as far as possible.

The BAR presents the relevant information to the Competent Authority for the purposes of decision making. In making a decision regarding this application the key findings must be considered as well as the other information contained within this report. The suggested mitigation measures must also be considered and compliance therewith should form a condition of any decision made to proceed with the development.

In addition, these conditions should be incorporated into a Construction Phase Environmental Management Plan which serves to guide and inform sustainable environmental practices during the construction process. The complete identified management and mitigation measures are listed in the accompanying EMPr.